

Up to 14.5 SEER, 12 EER, 8.0 HSPF, PACKAGE HEAT PUMP, 2 to 5 TONS

208/230-1-60 Single Phase

208/230-3-60 & 460-3-60 Three Phase

REFRIGERATION CIRCUIT

- Environmentally sound R-410A refrigerant
- Copper tube/aluminum fin condenser and evaporator coils
- Scroll compressor standard on all models
- Short-cycling protection for the compressor is built into the defrost control board
- Dehumidification mode (airflow reduction) on all models

EASY TO INSTALL AND SERVICE

- Installs easily on a rooftop or at ground level
- Easy three-panel accessibility for maintenance and installation
- Easily converts to down discharge applications
- Combination electric heating and cooling

BUILT TO LAST

- Direct drive high efficiency ECM blower motor on all models
- Pre-painted steel cabinet
- Vertical condenser fan discharge
- Full perimeter steel base rails
- High and low pressure switches provide added reliability for the compressor
- Single Phase models available with optional factory installed tin-coated copper evaporator coil with 3/8" spacing wire grilles standard as hail guard. All other models have 2" spacing wire grilles including 3 phase models.

(These models are identified with letters TP in the 11th and 12th positions in the model number)

LIMITED WARRANTY*

- 1 Phase PHD4 "E" Models
- 3 year No Hassle Replacement™ limited warranty for tin-coated 'TP' models
- 10 year parts limited warranty (including compressor and coils) with timely registration
- 5 year parts limited warranty if not registered within 90 days of original installation
- 3 Phase PHD4 "E" Models
- 5 year compressor limited warranty
- 1 year parts limited warranty

* See warranty certificate for details and restrictions



As an Energy Star® Partner, International Comfort Products has determined that this product meets the ENERGY STAR® guidelines for energy efficiency.



Use of the AHRI Certified TM Mark indicates a manufacturer's participation in the program. For verification of certification for individual products, go to www.ahridirectory.org.

| UNIT PERFORMANCE DATA | | | | | | | |
|--------------------------------------|-------------------|------|------|-------------------|------|---|------------------------------|
| Model Number | COOLING | | | HEATING | | Unit Dimensions Height x Width x Depth in (mm) | Operating Weight lbs (kg) |
| | Capacity BTU/h | SEER | EER | Capacity BTU/h | HSPF | | |
| 208/230-1-60 | | | | | | | |
| PHD424000KTP0E | 23,000 | 14.2 | 12.0 | 23,000 | 8.0 | 44 ³ / ₈ x 48 ³ / ₁₆ x 32 ⁵ / ₈ (1121 x 1224 x 829) | 348 (158) |
| PHD430000KTP0E | 28,600 | 14.2 | 12.0 | 29,600 | 8.0 | 44 ¹ / ₈ x 48 ³ / ₁₆ x 32 ⁵ / ₈ (1121 x 1224 x 829) | 340 (154) |
| PHD436000KTP0E | 35,800 | 14.5 | 12.0 | 35,800 | 8.0 | 44 ³ / ₄ x 48 ³ / ₁₆ x 44 ³ / ₁₆ (1137 x 1224 x 1122) | 418 (190) |
| PHD442000KTP0E | 40,500 | 14.5 | 12.0 | 41,500 | 8.0 | 48 ³ / ₄ x 48 ³ / ₁₆ x 44 ³ / ₁₆ (1238 x 1224 x 1122) | 464 (210) |
| PHD448000KTP0E | 46,500 | 14.5 | 12.0 | 45,500 | 8.0 | 48 ³ / ₄ x 48 ³ / ₁₆ x 44 ³ / ₁₆ (1238 x 1224 x 1122) | 452 (205) |
| PHD460000KTP0E | 57,000 | 14.5 | 12.0 | 59,000 | 8.0 | 54 ³ / ₄ x 48 ³ / ₁₆ x 44 ³ / ₁₆ (1391 x 1224 x 1122) | 506 (230) |
| 208/230-1-60 and 208/230-3-60 | | | | | | | |
| PHD424000K000E | 23,000 | 14.2 | 12.0 | 23,000 | 8.0 | 44 ¹ / ₈ x 48 ³ / ₁₆ x 32 ⁵ / ₈ (1121 x 1224 x 829) | 348 (158) |
| PHD430000K000E | 28,600 | 14.2 | 12.0 | 29,600 | 8.0 | 44 ¹ / ₈ x 48 ³ / ₁₆ x 32 ⁵ / ₈ (1121 x 1224 x 829) | 340 (154) |
| PHD436000K000E | 35,800 | 14.5 | 12.0 | 35,800 | 8.0 | 44 ³ / ₄ x 48 ³ / ₁₆ x 44 ³ / ₁₆ (1137 x 1224 x 1122) | 418 (190) |
| PHD442000K000E | 40,500 | 14.5 | 12.0 | 41,500 | 8.0 | 48 ³ / ₄ x 48 ³ / ₁₆ x 44 ³ / ₁₆ (1238 x 1224 x 1122) | 464 (210) |
| PHD448000K000E | 46,500 | 14.5 | 12.0 | 45,500 | 8.0 | 48 ³ / ₄ x 48 ³ / ₁₆ x 44 ³ / ₁₆ (1238 x 1224 x 1122) | 452 (205) |
| PHD460000K000E | 57,000 | 14.5 | 12.0 | 59,000 | 8.0 | 54 ³ / ₄ x 48 ³ / ₁₆ x 44 ³ / ₁₆ (1391 x 1224 x 1122) | 506 (230) |
| 460-3-60 | | | | | | | |
| PHD436000L000E | 35,800 | 14.5 | 12.0 | 35,800 | 8.0 | 44 ³ / ₄ x 48 ³ / ₁₆ x 44 ³ / ₁₆ (1137 x 1224 x 1122) | 432 (196) |
| PHD442000L000E | 40,500 | 14.5 | 12.0 | 41,500 | 8.0 | 48 ³ / ₄ x 48 ³ / ₁₆ x 44 ³ / ₁₆ (1238 x 1224 x 1122) | 476 (216) |
| PHD448000L000E | 46,500 | 14.5 | 12.0 | 45,500 | 8.0 | 48 ³ / ₄ x 48 ³ / ₁₆ x 44 ³ / ₁₆ (1238 x 1224 x 1122) | 466 (211) |
| PHD460000L000E | 57,000 | 14.5 | 12.0 | 59,000 | 8.0 | 54 ³ / ₄ x 48 ³ / ₁₆ x 44 ³ / ₁₆ (1391 x 1224 x 1122) | 520 (236) |

‡ - K = 208/230-1-60, H = 208/230-3-60

| MODEL NOMENCLATURE | | | | | | | | | | | |
|---|---|---|------|---|-----|---------------------------|----|-------|----|----|----|
| MODEL SERIES | 1 | 2 | 3 | 4 | 5,6 | 7,8,9 | 10 | 11,12 | 13 | 14 | 15 |
| | P | H | D | 4 | 36 | 000 | K | 00 | 0 | E | 1 |
| P = Package H = Heat Pump D = Standard 3 = 13 4 = 14 5 = 15 24 = 24,000 BTUH = 2 Tons 30 = 30,000 BTUH = 2.5 Tons 36 = 36,000 BTUH = 3 Tons 42 = 42,000 BTUH = 3.5 Tons 48 = 48,000 BTUH = 4 Tons 60 = 60,000 BTUH = 5 Tons 000 = no factory heat K = 208/230-1-60 H = 208/230-3-60 L = 460-3-60 00 = No options TP = Tin Plated Evaporator Main Tubes 0 = Standard Sales Model Digit Engineering Digit | | | | | | | | | | | |
| | | | TIER | | | | | | | | |
| SEER | | | | | | | | | | | |
| NOMINAL COOLING CAPACITY | | | | | | | | | | | |
| NOMINAL HEATING BTUH (input) | | | | | | | | | | | |
| | | | | | | VOLTAGE | | | | | |
| | | | | | | FACTORY INSTALLED OPTIONS | | | | | |
| | | | | | | FEATURE CODE | | | | | |

AHRI* CAPACITIES

COOLING CAPACITIES AND EFFICIENCIES

| UNIT | NOMINAL TONS | STANDARD CFM | COOLING CAPACITY | EER | SEER |
|------|--------------|--------------|------------------|------|------|
| 24 | 2 | 800 | 23000 | 12.0 | 14.2 |
| 30 | 2.5 | 1000 | 28600 | 12.0 | 14.2 |
| 36 | 3 | 1200 | 35800 | 12.0 | 14.5 |
| 42 | 3.5 | 1400 | 40500 | 12.0 | 14.5 |
| 48 | 4 | 1600 | 46500 | 12.0 | 14.5 |
| 60 | 5 | 1750 | 57000 | 12.0 | 14.5 |

Heat Pump Heating capacities and efficiencies

| UNIT | HEATING CAPACITY (BTUH) @ 47°F (8.3°C) | COP @ 47°F (8.3°C) | HEATING CAPACITY (BTUH) @ 17°F (-8.3°C) | COP @ 17°F (-8.3°C) | HSPF |
|------|--|--------------------|---|---------------------|------|
| 24 | 23000 | 3.5 | 11400 | 2.2 | 8.0 |
| 30 | 29600 | 3.5 | 15400 | 2.1 | 8.0 |
| 36 | 35800 | 3.5 | 19800 | 2.4 | 8.0 |
| 42 | 41500 | 3.4 | 23000 | 2.3 | 8.0 |
| 48 | 45500 | 3.4 | 26000 | 2.4 | 8.0 |
| 60 | 59000 | 3.5 | 32000 | 2.4 | 8.0 |

LEGEND

dB—Sound Levels (decibels)

db—Dry Bulb

SEER—Seasonal Energy Efficiency Ratio

wb—Wet Bulb

COP—Coefficient of Performance

HSPF—Heating Season Performance Factor

* Air Conditioning, Heating & Refrigeration Institute.

**At "A" conditions—80°F (26.7°C) indoor db/67°F (19.4°C) indoor wb & 95°F (35°C) outdoor db.

† Rated in accordance with U.S. Government DOE Department of Energy) test procedures and/or AHRI Standards 210/240.

Notes:

1. Ratings are net values, reflecting the effects of circulating fan heat.

Ratings are based on:

Cooling Standard: 80°F (26.7°C) db, 67°F (19.4°C) wb indoor entering—air temperature and 95°F (35°C) db outdoor entering—air temperature.

2. Before purchasing this appliance, read important energy cost and efficiency information available from your retailer.

PHYSICAL DATA

| UNIT SIZE | 24 | 30 | 36 | 42 | 48 | 60 | | |
|------------------------------------|-------------------|-----------|------------|-----------|------------|-----------|------------|--|
| NOMINAL CAPACITY (ton) | 2 | 2.5 | 3 | 3.5 | 4 | 5 | | |
| SHIPPING WEIGHT‡ (lb) | 354 | 346 | 426 | 472 | 460 | 515 | | |
| (kg) | 161 | 157 | 193 | 214 | 209 | 234 | | |
| COMPRESSOR QUANTITY | 1 | | | | | | | |
| TYPE | SCROLL COMPRESSOR | | | | | | | |
| REFRIGERANT | R-410A | | | | | | | |
| REFRIGERANT QUANTITY (lb) | 11.1 | 10.3 | 9.9 | 11.3 | 12.5 | 15.2 | | |
| QUANTITY (kg) | 5.0 | 4.7 | 4.5 | 5.1 | 5.7 | 6.9 | | |
| METERING DEVICE ID | TXV | | | | | | | |
| ORIFICE OD (in.) | 0.032 (2) | 0.037 (2) | 0.038 (2) | 0.040 (2) | 0.040 (2) | 0.049 (2) | | |
| (mm) | 0.81 (2) | 0.94 (2) | 0.97 (2) | 1.02 (2) | 1.02 (2) | 1.24 (2) | | |
| OUTDOOR COIL | | | | | | | | |
| ROWS..FINS/in. | 2..21 | 2..21 | 2..21 | 2..21 | 2..21 | 2..21 | | |
| FACE AREA (sq. ft) | 13.6 | 13.6 | 13.6 | 17.5 | 17.5 | 23.3 | | |
| OUTDOOR FAN | | | | | | | | |
| NOMINAL AIRFLOW | 2500 | 2700 | 3100 | 3100 | 3100 | 3800 | | |
| DIAMETER (in.) | 24 | 24 | 26 | 26 | 26 | 26 | | |
| DIAMETER (mm) | 610 | 610 | 660 | 660 | 660 | 660 | | |
| MOTOR HP (RPM) | 1/10 (810) | 1/5 (810) | 1/5 (810) | 1/5 (810) | 1/5 (810) | 1/4 (810) | | |
| INDOOR COIL | | | | | | | | |
| ROWS..FINS/in. | 3..17 | 3..17 | 3..17 | 3..17 | 3..17 | 3..17 | | |
| FACE AREA (sq. ft) | 3.7 | 3.7 | 4.7 | 4.7 | 5.6 | 5.6 | | |
| INDOOR BLOWER | | | | | | | | |
| NOMINAL COOLING AIRFLOW (cfm) | 800 | 1000 | 1200 | 1400 | 1600 | 1750 | | |
| SIZE (in.) | 10x10 | 10x10 | 11x10 | 11x10 | 11x10 | 11x10 | | |
| (mm) | 254x254 | 254x254 | 279x254 | 279x254 | 279x254 | 279x254 | | |
| MOTOR (HP) | 1/2 | 1/2 | 3/4 | 3/4 | 1 | 1 | | |
| HIGH-PRESSURE SWITCH (psig) | 650 ± 15 | | | | | | | |
| CUTOFF | 420 ± 25 | | | | | | | |
| RESET (AUTO) | | | | | | | | |
| LOSS-OF-CHARGE/LOW-PRESSURE SWITCH | 20 ± 5 | | | | | | | |
| LIQUID LINE (psig) | 45 ± 10 | | | | | | | |
| CUTOFF | | | | | | | | |
| RESET (AUTO) | | | | | | | | |
| RETURN-AIR FILTERS*† | 20x20x1 | | 20x24x1 | | 24x30x1 | | 24x36x1 | |
| THROWAWAY (in.) | 508x508x25 | | 508x610x25 | | 610x762x25 | | 610x914x25 | |
| (mm) | | | | | | | | |

*Required filter sizes shown are based on the larger of the AHRI (Air Conditioning, Heating and Refrigeration Institute) rated cooling airflow or the heating airflow velocity of 300 ft/minute for throwaway type or 450 ft/minute for high-capacity type. Air filter pressure drop for non-standard filters must not exceed 0.08 IN. W.C.

† If using accessory filter rack refer to the filter rack installation instructions for correct filter size and quantity.

‡ For 460 volt units, add 14 lb (6.4 kg) to the weight.

A-WEIGHTED SOUND POWER LEVEL (dBA)

| UNIT | Standard Rating (dBA) | TYPICAL OCTAVE BAND SPECTRUM (Dda) (without tone adjustment) | | | | | | |
|------|-----------------------|--|------|------|------|------|------|------|
| | | 125 | 250 | 500 | 1000 | 2000 | 4000 | 8000 |
| 24 | 74 | 63.5 | 64.5 | 69 | 69.5 | 65 | 59.5 | 50 |
| 30 | 75 | 63.5 | 66 | 71 | 69.5 | 66.5 | 61 | 54 |
| 36 | 74 | 64 | 66 | 68 | 68 | 66.5 | 60.5 | 52 |
| 42 | 73 | 63.5 | 63.5 | 66.5 | 67 | 64.5 | 60 | 52.5 |
| 48 | 74 | 68.5 | 65 | 67 | 67.5 | 65 | 60.5 | 53 |
| 60 | 75 | 68 | 64.5 | 68.5 | 69 | 65.5 | 62 | 58 |

NOTE: Tested in accordance with AHRI Standard 270-1995 (not listed in AHRI).

Electric Heaters

| ORDERING NO. | NOMINAL CAPACITY (kW @ 240 or 480 VOLTS) | USED WITH SIZES | | | | | |
|---------------------------------------|--|-----------------|----|----|----|----|----|
| | | 24 | 30 | 36 | 42 | 48 | 60 |
| 208/230 – SINGLE PHASE – 60 HZ | | | | | | | |
| CPHEATER052A0* | 5.0 | X | X | X | | | |
| CPHEATER064A0* | 5.0 | X | X | X | X | X | X |
| CPHEATER070A0* | 7.2 | X | X | X | X | X | X |
| CPHEATER050A0* | 10.0 | X | X | X | X | X | X |
| CPHEATER066A0* | 15.0 | | X | X | X | X | X |
| CPHEATER054A0* | 20.0 | | | | X | X | X |
| 208/230 – THREE PHASE – 60 HZ | | | | | | | |
| CPHEATER055A0* | 5.0 | | X | X | X | X | X |
| CPHEATER056A0* | 10.0 | | X | X | X | | |
| CPHEATER068A0* | 10.0 | | X | X | X | X | X |
| CPHEATER058A0* | 15.0 | | X | X | X | X | X |
| CPHEATER059A0* | 20.0 | | | | X | X | X |
| 460 – THREE PHASE – 60 HZ | | | | | | | |
| CPHEATER061A0* | 10.0 | | | X | X | X | X |
| CPHEATER062A0* | 15.0 | | | X | X | X | X |
| CPHEATER063A0* | 20.0 | | | | X | X | X |

NOTE: Electric heaters are rated at 240v. Refer to Multiplication Factors table for other voltages.

X = Approved combination

Minimum Airflow for Reliable Electric Heater Operation (CFM)

| SIZE | 24 | 30 | 36 | 42 | 48 | 60 |
|---------------|-----|------|------|------|------|------|
| AIRFLOW (CFM) | 800 | 1025 | 1250 | 1400 | 1710 | 1800 |

ECONOMIZER

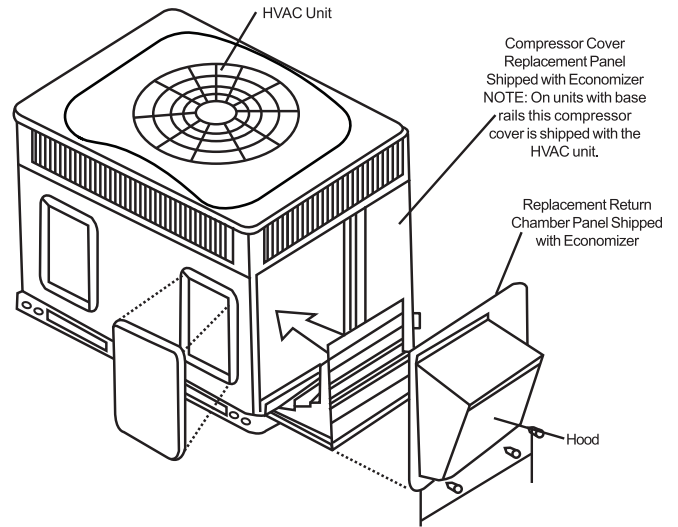
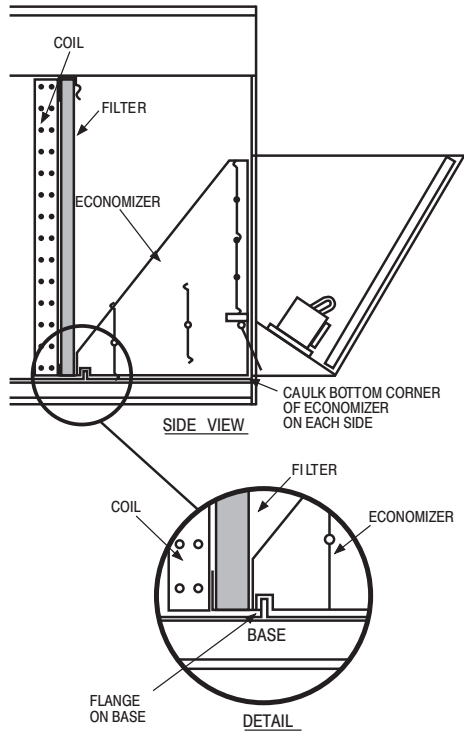

Vertical Economizer

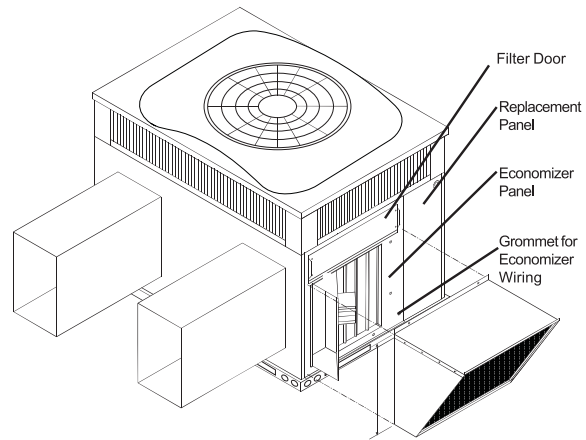

Horizontal Economizer

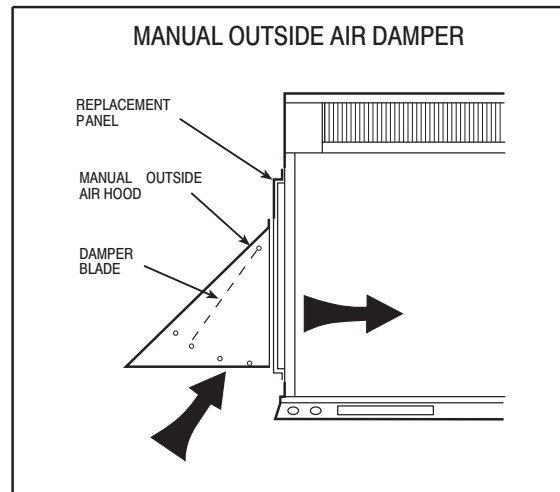
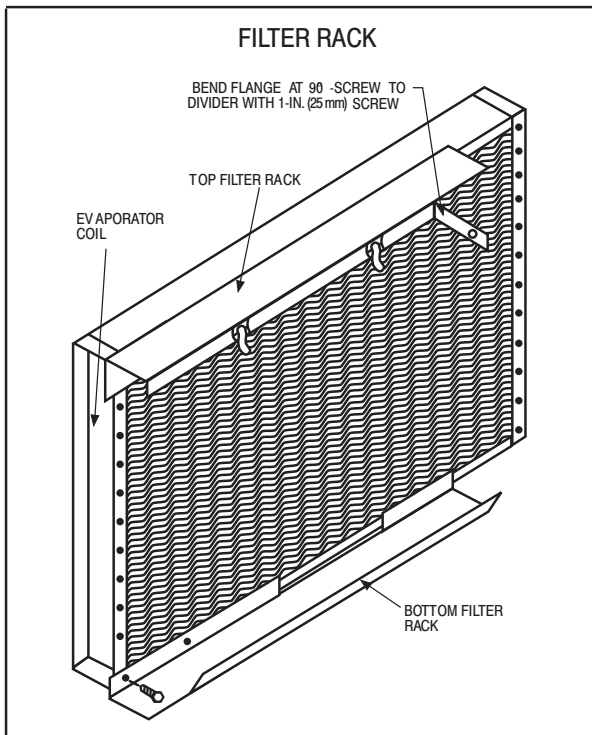

UNIT DIMENSIONS - 24-30

REQUIRED CLEARANCES TO COMBUSTIBLE MATL.

| | INCHES [MM] |
|--------------------------|-------------|
| TOP OF UNIT..... | 14 [355.6] |
| DUCT SIDE OF UNIT..... | 2 [50.8] |
| SIDE OPPOSITE DUCTS..... | 14 [355.6] |
| BOTTOM OF UNIT..... | 0 [0.0] |
| ELECTRICAL PANEL..... | 36 [914.4] |

NEC. REQUIRED CLEARANCES.

| | INCHES [MM] |
|---|-------------|
| BETWEEN UNITS, POWER ENTRY SIDE..... | 42 [1066.8] |
| UNIT AND UNGROUNDED SURFACES, POWER ENTRY SIDE..... | 36 [914.0] |
| UNIT AND BLOCK OR CONCRETE WALLS AND OTHER GROUNDED SURFACES, POWER ENTRY SIDE..... | 42 [1066.8] |

REQUIRED CLEARANCE FOR OPERATION AND SERVICING

| | INCHES [MM] |
|-------------------------------|-------------|
| EVAP. COIL ACCESS SIDE..... | 36 [914.0] |
| POWER ENTRY SIDE..... | 42 [1066.8] |
| (EXCEPT FOR NEC REQUIREMENTS) | |
| UNIT TOP..... | 48 [1219.2] |
| SIDE OPPOSITE DUCTS..... | 36 [914.0] |
| DUCT PANEL..... | 12 [304.8] |

*MINIMUM DISTANCES: IF UNIT IS PLACED LESS THAN 12 [304.8] FROM WALL SYSTEM, THEN SYSTEM PERFORMANCE MAY BE COMPROMISED.

DIMENSIONS IN [] ARE IN MILLIMETERS

| UNIT | SERIES | ELECTRICAL CHARACTERISTICS | UNIT WT. | | UNIT HEIGHT IN/MM | | | CENTER OF GRAVITY IN/MM | | | | |
|--------|--------|----------------------------|----------|-----|-------------------|------|--------|-------------------------|--------|-----|--------|-----|
| | | | LB | KG | "A" | | | X | Y | Z | | |
| PHD424 | 1 | 208/230-1 | 348 | 158 | 44-1/8 | 1121 | 20-1/2 | 521 | 15-1/2 | 394 | 16-1/2 | 419 |
| PHD430 | 1 | 208/230-1, 208/230-3-60 | 340 | 154 | 44-1/8 | 1121 | 20-1/2 | 521 | 15-1/2 | 394 | 16-1/2 | 419 |

| UNITS | VOLTAGE | CORNER WEIGHT LB/KG | | | | | | | |
|--------|---------|---------------------|-----|-----|-----|----|----|-----|----|
| | | "1" | "2" | "3" | "4" | | | | |
| PHD424 | 208/230 | 93 | 42 | 73 | 33 | 80 | 36 | 102 | 46 |
| PHD430 | 208/230 | 90 | 41 | 71 | 32 | 79 | 36 | 100 | 45 |

NOTE: ALL TABLE DATA RELEVANT FOR ALL FACTORY INSTALLED OPTIONS EXCEPT ECONOMIZER

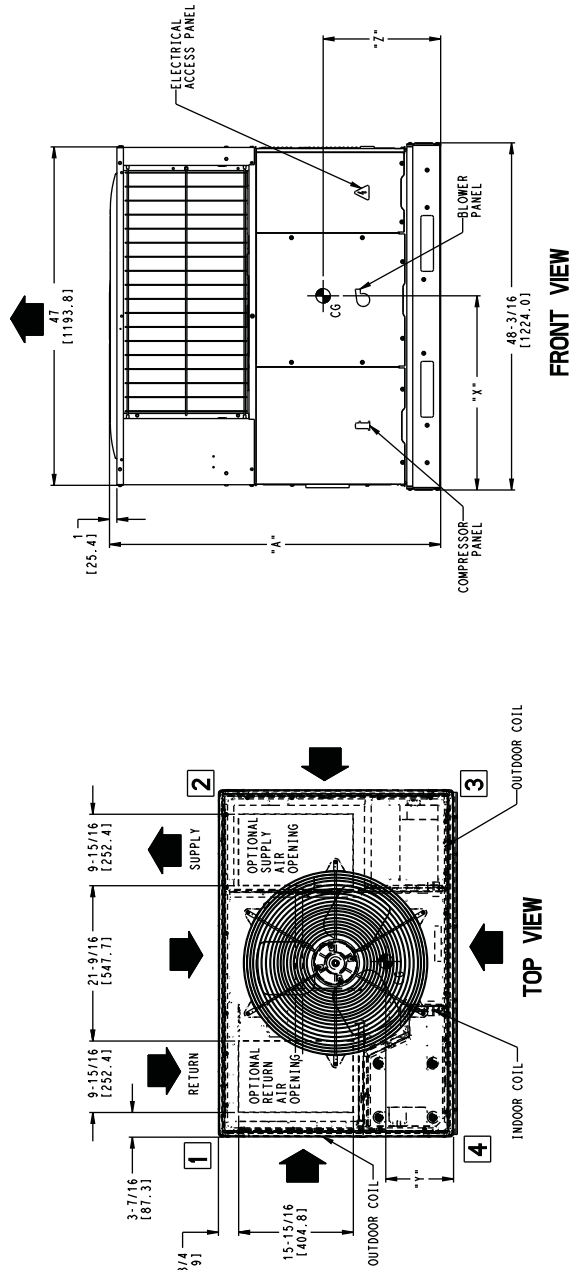

UNIT DIMENSIONS - 36-60

REQUIRED CLEARANCES TO COMBUSTIBLE MATL.

| | INCHES [MM] |
|--------------------------|-------------|
| TOP OF UNIT..... | 14 [355.6] |
| DUCT SIDE OF UNIT..... | 2 [50.8] |
| SIDE OPPOSITE DUCTS..... | 14 [355.6] |
| BOTTOM OF UNIT..... | 0 [0.0] |
| ELECTRICAL PANEL..... | 36 [914.4] |

NEC REQUIRED CLEARANCES.

| | INCHES [MM] |
|---|-------------|
| BETWEEN UNITS, POWER ENTRY SIDE..... | 42 [1066.8] |
| UNIT AND UNGROUNDED SURFACES, POWER ENTRY SIDE..... | 36 [914.0] |
| UNIT AND BLOCK OR CONCRETE WALLS AND OTHER GROUNDED SURFACES, POWER ENTRY SIDE..... | 42 [1066.8] |

REQUIRED CLEARANCE FOR OPERATION AND SERVICING

| | INCHES [MM] |
|-------------------------------|-------------|
| EVAP. COIL ACCESS SIDE..... | 36 [914.0] |
| POWER ENTRY SIDE..... | 42 [1066.8] |
| (EXCEPT FOR NEC REQUIREMENTS) | |
| UNIT TOP..... | 48 [1219.2] |
| SIDE OPPOSITE DUCTS..... | 36 [914.0] |
| DUCT PANEL..... | 12 [304.8]* |

*MINIMUM DISTANCES-IF UNIT IS PLACED LESS THAN 12 [304.8] FROM WALL SYSTEM, THEN SYSTEM PERFORMANCE MAYBE COMPROMISED.

DIMENSIONS IN [] ARE IN MM

| UNIT | SERIES | ELECTRICAL CHARACTERISTICS | UNIT WT. | | CENTER OF GRAVITY IN/MM | | | | | | | |
|--------|--------|----------------------------|----------|-----|-------------------------|------|--------|-----|--------|-----|--------|-----|
| | | | LB | KG | X | Y | Z | | | | | |
| PHD436 | 1 | 208/230-1, 208/230-3-60 | 418 | 190 | 44-3/4 | 1137 | 20-1/2 | 521 | 17-1/2 | 445 | 17-3/8 | 441 |
| | 1 | 460-3-60 | 432 | 196 | 44-3/4 | 1137 | 20-1/2 | 521 | 17-1/2 | 445 | 17-3/8 | 441 |
| PHD442 | 1 | 208/230-1, 208/230-3-60 | 464 | 210 | 48-3/4 | 1238 | 20-1/2 | 521 | 17-1/2 | 445 | 17-3/8 | 448 |
| | 1 | 460-3-60 | 476 | 216 | 48-3/4 | 1238 | 20-1/2 | 521 | 17-1/2 | 445 | 17-3/8 | 448 |
| PHD448 | 1 | 208/230-1, 208/230-3-60 | 452 | 205 | 48-3/4 | 1238 | 20-1/2 | 521 | 17-1/2 | 445 | 17-3/8 | 448 |
| | 1 | 460-3-60 | 466 | 211 | 48-3/4 | 1238 | 20-1/2 | 521 | 17-1/2 | 445 | 17-3/8 | 448 |
| PHD460 | 1 | 208/230-1, 208/230-3-60 | 506 | 230 | 54-3/4 | 1391 | 20-1/2 | 521 | 17-1/2 | 445 | 18 | 457 |
| | 1 | 460-3-60 | 520 | 236 | 54-3/4 | 1391 | 20-1/2 | 521 | 17-1/2 | 445 | 18 | 457 |

| UNIT | VOLTAGE | CORNER WEIGHTS LB/KG | | | | | | | |
|--------|---------|----------------------|-----|-----|-----|-----|----|-----|----|
| | | *1* | *2* | *3* | *4* | | | | |
| PHD436 | 208/230 | 92 | 42 | 73 | 33 | 111 | 50 | 142 | 64 |
| | 460 | 96 | 43 | 75 | 34 | 115 | 52 | 146 | 66 |
| PHD442 | 208/230 | 103 | 47 | 81 | 37 | 124 | 56 | 157 | 71 |
| | 460 | 105 | 48 | 83 | 38 | 127 | 57 | 161 | 73 |
| PHD448 | 208/230 | 100 | 45 | 79 | 36 | 120 | 55 | 153 | 69 |
| | 460 | 103 | 47 | 81 | 37 | 124 | 56 | 158 | 72 |
| PHD460 | 208/230 | 112 | 51 | 88 | 40 | 135 | 61 | 171 | 78 |
| | 460 | 115 | 52 | 90 | 41 | 138 | 63 | 176 | 80 |

NOTE: ALL TABLE DATA RELEVANT FOR ALL FACTORY INSTALLED OPTIONS EXCEPT ECONOMIZER

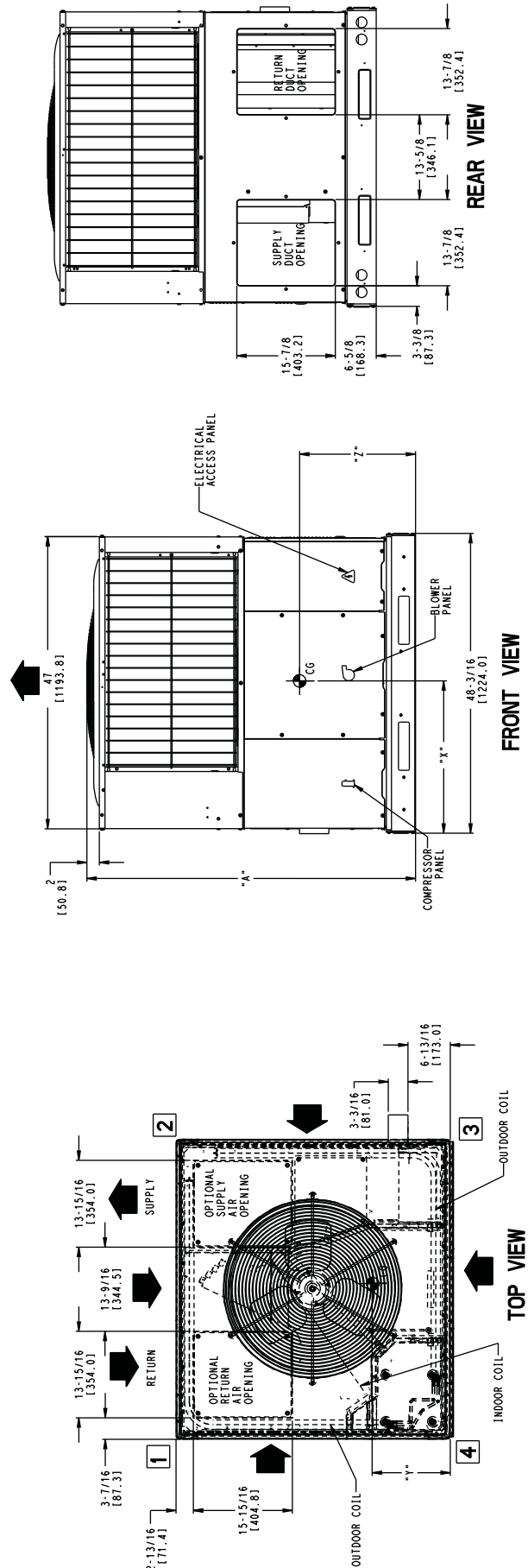

ROOF CURB ACCESSORY DIMENSIONS

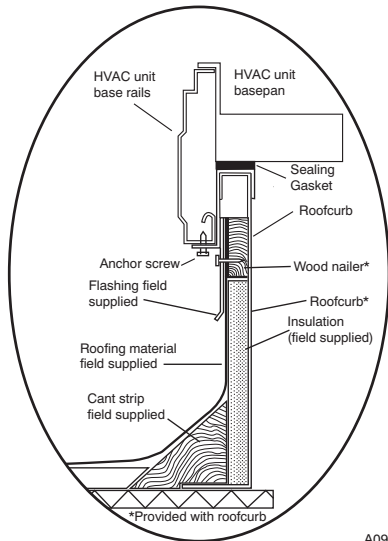

ROOF CURB DETAIL

A09090

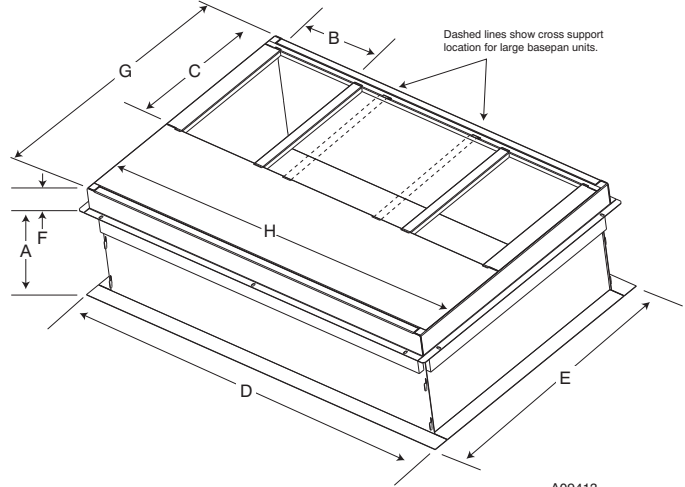

SMALL/COMMON CURB

A09413

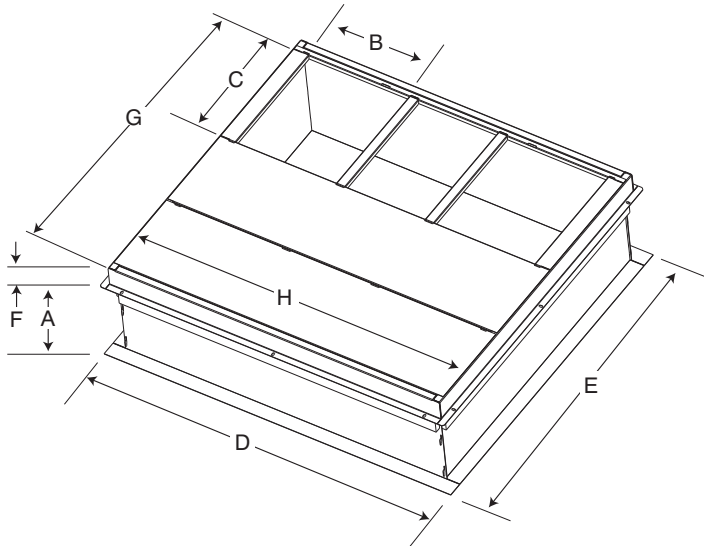

LARGE CURB

A09415

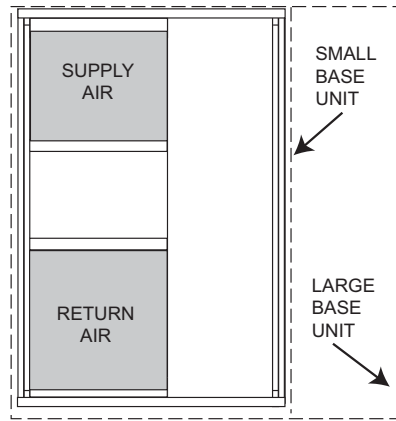

UNIT PLACEMENT ON COMMON CURB

A09094

SMALL OR LARGE BASE UNIT

A09414

| UNIT SIZE | CATALOG NUMBER | A IN. (mm) | B (small/common base) IN. (mm)* | B (large base) IN. (mm)* | C IN. (mm) | D IN. (mm) | E IN. (mm) | F IN. (mm) | G IN. (mm) | H IN. (mm) |
|----------------|----------------|------------|---------------------------------|--------------------------|------------|-------------|-------------|------------|-------------|-------------|
| Small or Large | CPRFCURB010A00 | 11 (279) | 10 (254) | 14 (356) | 16 (406) | 47.8 (1214) | 32.4 (822) | 2.7 (69) | 30.6 (778) | 46.1 (1170) |
| | CPRFCURB011A00 | 14 (356) | | | | | | | | |
| Large | CPRFCURB012A00 | 11 (279) | 14 (356) | 14 (356) | 16 (406) | 47.8 (1214) | 43.9 (1116) | 2.7 (69) | 42.2 (1072) | 46.1 (1170) |
| | CPRFCURB013A00 | 14 (356) | | | | | | | | |

* Part Numbers CPRFCURB010A00 and CPRFCURB011A00 can be used on both small and large basepan units. The cross supports must be located based on whether the unit is a small basepan or a large basepan.

NOTES:

1. Roof curb must be set up for unit being installed.
2. Seal strip must be applied, as required, to unit being installed.
3. Roof curb is made of 16-gauge steel.
4. Attach ductwork to curb (flanges of duct rest on curb).
5. Insulated panels: 1-in. (25 mm) thick fiberglass 1 lb. density.

SELECTION PROCEDURE (WITH EXAMPLE)

1. Determine cooling and heating requirements at design conditions:

Given:

Required Cooling Capacity (TC) 34,500 Btuh
Sensible Heat Capacity (SHC) 26,000 Btuh
Required Heating Capacity 60,000 Btuh
Condenser Entering Air Temperature . . . 95°F (35°C)
Indoor–Air Temperature 80°F (27°C) edb 67°F (19°C) ewb
Evaporator Air Quantity 1200 CFM
External Static Pressure 0.200 IN. W.C.
Electrical Characteristics 208–1–60

2. Select unit based on required cooling capacity.

Enter Net Cooling Capacities table at condenser entering temperature of 95°F (35°C). Unit 36 at 1200 CFM and 67°F (19°C) ewb (entering wet bulb) will provide a total capacity of 35,800 Btuh and a SHC of 26,950 Btuh. Calculate SHC correction, if required, using Note 4 under Cooling Capacities tables.

3. Select heating capacity of unit to provide design condition requirement.

In the Heating Capacities and Efficiencies table, note that the 36 size unit will deliver 34,800 BTUH at the AHRI high temp rating point. To achieve 60,000 BTUH, accessory electric heat will be required. Use the Balance Point Worksheet to plot the load line with the unit capacity. The difference between the load line and unit capacity at the design heating temperature is the amount of electric heat that will be required.

4. Determine fan speed and power requirements at design conditions.

Before entering the air delivery tables, calculate the total static pressure required. From the given example, the Wet Coil Pressure Drop Table, and the Filter Pressure Drop Table:

| | |
|--------------------------|----------------------|
| External Static Pressure | 0.200 IN. W.C. |
| Filter | 0.130 IN. W.C. |
| Wet Coil Pressure Drop | <u>0.18</u> IN. W.C. |
| Total Static Pressure | 0.51 IN. W.C. |

Enter the table for Dry Coil Air Delivery— At 0.50 IN. W.C. ESP (external static pressure) and MED–LOW speed the motor delivers 1140 CFM. To achieve 1200 CFM, a higher speed tap is required.

5. Select unit that corresponds to power source available.

The Electrical Data Table shows that the unit is designed to operate at 208/230–1–60.

PERFORMANCE DATA

24 Cooling Extended Performance Table

| EVAPORATOR AIR | | CONDENSER ENTERING AIR TEMPERATURES deg F (deg C) | | | | | | | | | | | | | | | | | |
|----------------|--------------|---|-------|--------------|----------------|-------|--------------|----------------|-------|--------------|----------------|-------|--------------|----------------|-------|--------------|----------------|-------|--------------|
| CFM | EWB | 75 (23.9) | | | 85 (29.4) | | | 95 (35) | | | 105 (40.6) | | | 115 (46.1) | | | 125 (51.7) | | |
| | | Capacity MBtuh | Sens | Total Sys kW | Capacity MBtuh | Sens | Total Sys kW | Capacity MBtuh | Sens | Total Sys kW | Capacity MBtuh | Sens | Total Sys kW | Capacity MBtuh | Sens | Total Sys kW | Capacity MBtuh | Sens | Total Sys kW |
| 700 | 57 (13.9) | 21.90 | 21.90 | 1.50 | 21.04 | 21.04 | 1.68 | 20.11 | 20.11 | 1.88 | 19.10 | 19.10 | 2.10 | 18.03 | 18.03 | 2.35 | 16.87 | 16.87 | 2.64 |
| | 62 (16.7) | 22.70 | 20.36 | 1.50 | 21.63 | 19.79 | 1.68 | 20.49 | 19.17 | 1.88 | 19.30 | 18.47 | 2.10 | 18.08 | 18.08 | 2.35 | 16.90 | 16.90 | 2.64 |
| | 63 (17.2) | 23.06 | 16.63 | 1.50 | 21.94 | 16.09 | 1.68 | 20.75 | 15.53 | 1.88 | 19.50 | 14.94 | 2.11 | 18.17 | 14.31 | 2.36 | 16.75 | 13.64 | 2.64 |
| | 67 (19.4) | 24.96 | 17.37 | 1.50 | 23.75 | 16.83 | 1.69 | 22.46 | 16.26 | 1.89 | 21.12 | 15.67 | 2.12 | 19.68 | 15.04 | 2.37 | 18.16 | 14.37 | 2.65 |
| | 72 (22.2) | 27.48 | 14.25 | 1.51 | 26.12 | 13.75 | 1.70 | 24.71 | 13.19 | 1.91 | 23.23 | 12.61 | 2.14 | 21.65 | 12.00 | 2.39 | 19.99 | 11.36 | 2.67 |
| | 57 (13.9) | 22.97 | 22.97 | 1.52 | 22.03 | 22.03 | 1.70 | 21.03 | 21.03 | 1.90 | 19.95 | 19.95 | 2.13 | 18.79 | 18.79 | 2.38 | 17.55 | 17.55 | 2.66 |
| | 62 (16.7) | 23.39 | 21.91 | 1.52 | 22.27 | 21.26 | 1.70 | 21.10 | 21.08 | 1.90 | 19.98 | 19.98 | 2.13 | 18.82 | 18.82 | 2.38 | 17.58 | 17.58 | 2.66 |
| 800 | 63 (17.2) | 23.69 | 17.76 | 1.52 | 22.51 | 17.20 | 1.70 | 21.26 | 16.61 | 1.91 | 19.94 | 15.99 | 2.13 | 18.56 | 15.33 | 2.38 | 17.09 | 14.61 | 2.66 |
| | 67 (19.4) | 25.63 | 18.59 | 1.52 | 24.34 | 18.02 | 1.71 | 23.00 | 17.43 | 1.92 | 21.58 | 16.80 | 2.14 | 20.09 | 16.14 | 2.39 | 18.51 | 15.43 | 2.67 |
| | 72 (22.2) | 28.18 | 15.05 | 1.53 | 26.77 | 14.50 | 1.73 | 25.28 | 13.93 | 1.93 | 23.72 | 13.32 | 2.16 | 22.08 | 12.68 | 2.41 | 20.35 | 12.02 | 2.69 |
| | 57 (13.9) | 23.89 | 23.89 | 1.54 | 22.88 | 22.88 | 1.72 | 21.81 | 21.81 | 1.93 | 20.66 | 20.66 | 2.15 | 19.43 | 19.43 | 2.40 | 18.11 | 18.11 | 2.69 |
| | 62 (16.7) | 24.03 | 23.26 | 1.54 | 22.92 | 22.92 | 1.72 | 21.85 | 21.85 | 1.93 | 20.69 | 20.69 | 2.15 | 19.46 | 19.46 | 2.40 | 18.14 | 18.14 | 2.69 |
| | 63 (17.2) | 24.20 | 18.85 | 1.54 | 22.96 | 18.26 | 1.72 | 21.66 | 17.64 | 1.93 | 20.30 | 16.99 | 2.15 | 18.86 | 16.29 | 2.40 | 17.35 | 15.52 | 2.68 |
| | 67 (19.4) | 26.16 | 19.77 | 1.54 | 24.82 | 19.18 | 1.73 | 23.42 | 18.55 | 1.94 | 21.95 | 17.89 | 2.16 | 20.41 | 17.19 | 2.41 | 18.78 | 16.43 | 2.69 |
| 72 (22.2) | 28.76 | 15.79 | 1.55 | 27.27 | 15.22 | 1.75 | 25.73 | 14.62 | 1.95 | 24.11 | 14.00 | 2.18 | 22.41 | 13.34 | 2.43 | 20.62 | 12.64 | 2.71 | |

*At 75°F (23.9 °C) entering dry bulb—Tennessee Valley Authority (TVA) rating conditions; all others at 80°F (26.7 °C) entering dry bulb. See Legend and Notes.

24 Heating Extended Performance Table -10-60 (-23.3-15.6 °C)

| INDOOR AIR | | OUTDOOR COIL ENTERING AIR TEMPERATURES deg F (deg C) | | | | | | | | | | | | | | | | | | | | | | | |
|--------------|-----|--|------|--------------|----------------|------|--------------|----------------|-------|--------------|----------------|-------|--------------|----------------|-------|--------------|----------------|-------|--------------|----------------|-------|--------------|----------------|-------|--------------|
| EDB | CFM | -10 (-23.3) | | | 0 (-17.8) | | | 10 (-12.2) | | | 20 (-6.7) | | | 30 (-1.1) | | | 40 (4.4) | | | 50 (10) | | | 60 (15.6) | | |
| | | Capacity MBtuh | Sens | Total Sys kW | Capacity MBtuh | Sens | Total Sys kW | Capacity MBtuh | Sens | Total Sys kW | Capacity MBtuh | Sens | Total Sys kW | Capacity MBtuh | Sens | Total Sys kW | Capacity MBtuh | Sens | Total Sys kW | Capacity MBtuh | Sens | Total Sys kW | Capacity MBtuh | Sens | Total Sys kW |
| 65 (18.3) | 700 | 7.13 | 6.56 | 1.48 | 9.45 | 8.70 | 1.55 | 12.07 | 11.08 | 1.62 | 14.83 | 13.45 | 1.68 | 17.57 | 15.40 | 1.74 | 20.64 | 20.64 | 1.81 | 24.12 | 24.12 | 1.90 | 28.24 | 28.24 | 2.03 |
| | 800 | 7.23 | 6.65 | 1.49 | 9.58 | 8.81 | 1.55 | 12.45 | 11.43 | 1.62 | 14.96 | 13.57 | 1.67 | 17.75 | 15.55 | 1.72 | 20.87 | 20.87 | 1.78 | 24.44 | 24.44 | 1.86 | 28.65 | 28.65 | 1.98 |
| | 900 | 7.32 | 6.74 | 1.50 | 9.68 | 8.91 | 1.56 | 12.55 | 11.52 | 1.61 | 15.09 | 13.68 | 1.66 | 17.90 | 15.68 | 1.71 | 21.07 | 21.07 | 1.76 | 24.69 | 24.69 | 1.84 | 28.85 | 28.85 | 1.95 |
| 70 (21.1) | 700 | 6.86 | 6.31 | 1.55 | 9.18 | 8.45 | 1.62 | 11.73 | 10.77 | 1.69 | 14.64 | 13.28 | 1.76 | 17.32 | 15.17 | 1.83 | 20.33 | 20.33 | 1.90 | 23.72 | 23.72 | 1.99 | 27.75 | 27.75 | 2.12 |
| | 800 | 6.97 | 6.41 | 1.55 | 9.31 | 8.57 | 1.62 | 11.89 | 10.92 | 1.68 | 14.77 | 13.40 | 1.75 | 17.50 | 15.33 | 1.80 | 20.57 | 20.57 | 1.87 | 24.04 | 24.04 | 1.95 | 28.17 | 28.17 | 2.07 |
| | 900 | 7.06 | 6.50 | 1.56 | 9.42 | 8.67 | 1.62 | 12.03 | 11.04 | 1.68 | 14.90 | 13.51 | 1.74 | 17.65 | 15.47 | 1.79 | 20.76 | 20.76 | 1.85 | 24.29 | 24.29 | 1.93 | 28.44 | 28.44 | 2.04 |
| 75 (23.9) | 700 | 6.56 | 6.03 | 1.62 | 8.88 | 8.17 | 1.69 | 11.42 | 10.48 | 1.76 | 14.43 | 13.09 | 1.85 | 17.06 | 14.95 | 1.91 | 20.03 | 20.03 | 1.99 | 23.35 | 23.35 | 2.09 | 27.26 | 27.26 | 2.22 |
| | 800 | 6.67 | 6.13 | 1.62 | 9.02 | 8.30 | 1.69 | 11.57 | 10.62 | 1.75 | 14.57 | 13.22 | 1.83 | 17.24 | 15.11 | 1.89 | 20.26 | 20.26 | 1.96 | 23.65 | 23.65 | 2.04 | 27.67 | 27.67 | 2.17 |
| | 900 | 6.76 | 6.22 | 1.63 | 9.13 | 8.40 | 1.70 | 11.71 | 10.75 | 1.75 | 14.69 | 13.32 | 1.82 | 17.40 | 15.24 | 1.87 | 20.45 | 20.45 | 1.94 | 23.89 | 23.89 | 2.02 | 27.96 | 27.96 | 2.14 |

PERFORMANCE DATA (CONT)

30 Cooling Extended Performance Table

| EVAPORATOR AIR | | CONDENSER ENTERING AIR TEMPERATURES deg F (deg C) | | | | | | | | | | | | | | | | | |
|----------------|-----------|---|--------------|-------|----------------|--------------|------|----------------|--------------|-------|----------------|--------------|------|----------------|--------------|-------|----------------|--------------|------|
| CFM | EWB | 75 (23.9) | | | 85 (28.4) | | | 95 (35) | | | 105 (40.6) | | | 115 (46.1) | | | 125 (51.7) | | |
| | | Capacity MBtuh | Total Sys kW | Sens | Capacity MBtuh | Total Sys kW | Sens | Capacity MBtuh | Total Sys kW | Sens | Capacity MBtuh | Total Sys kW | Sens | Capacity MBtuh | Total Sys kW | Sens | Capacity MBtuh | Total Sys kW | Sens |
| 875 | 57 (13.9) | 27.14 | 1.89 | 26.11 | 2.10 | 25.02 | 2.33 | 23.84 | 2.59 | 22.53 | 2.89 | 21.09 | 2.89 | 21.09 | 2.89 | 21.09 | 2.89 | 21.09 | 2.89 |
| | 62 (16.7) | 28.06 | 1.90 | 24.93 | 2.10 | 25.43 | 2.33 | 24.02 | 2.59 | 22.57 | 2.89 | 21.13 | 2.89 | 21.13 | 2.89 | 21.13 | 2.89 | 21.13 | 2.89 |
| | 63 (17.2) | 28.55 | 1.90 | 20.23 | 2.10 | 25.81 | 2.33 | 24.31 | 2.59 | 22.68 | 2.89 | 20.91 | 2.89 | 20.91 | 2.89 | 20.91 | 2.89 | 20.91 | 2.89 |
| | 67 (19.4) | 30.91 | 1.91 | 21.79 | 2.12 | 27.96 | 2.35 | 26.35 | 2.61 | 24.61 | 2.90 | 19.06 | 2.90 | 19.06 | 2.90 | 19.06 | 2.90 | 19.06 | 2.90 |
| | 72 (22.2) | 34.14 | 1.93 | 17.72 | 2.14 | 30.88 | 2.37 | 29.10 | 2.63 | 27.19 | 2.92 | 15.17 | 2.92 | 15.17 | 2.92 | 15.17 | 2.92 | 15.17 | 2.92 |
| 1000 | 57 (13.9) | 28.46 | 1.93 | 27.34 | 2.14 | 26.16 | 2.37 | 24.89 | 2.63 | 23.49 | 2.92 | 21.96 | 2.92 | 21.96 | 2.92 | 21.96 | 2.92 | 21.96 | 2.92 |
| | 62 (16.7) | 28.88 | 1.93 | 27.56 | 2.14 | 26.22 | 2.37 | 24.94 | 2.63 | 23.53 | 2.92 | 21.99 | 2.92 | 21.99 | 2.92 | 21.99 | 2.92 | 21.99 | 2.92 |
| | 63 (17.2) | 29.30 | 1.93 | 22.31 | 2.14 | 26.41 | 2.37 | 24.85 | 2.63 | 23.15 | 2.92 | 18.57 | 2.92 | 18.57 | 2.92 | 18.57 | 2.92 | 18.57 | 2.92 |
| | 67 (19.4) | 31.70 | 1.95 | 23.35 | 2.15 | 28.60 | 2.38 | 26.91 | 2.64 | 25.10 | 2.93 | 20.49 | 2.93 | 20.49 | 2.93 | 20.49 | 2.93 | 20.49 | 2.93 |
| | 72 (22.2) | 35.00 | 1.97 | 18.77 | 2.18 | 31.53 | 2.41 | 29.69 | 2.66 | 27.70 | 2.95 | 16.07 | 2.95 | 16.07 | 2.95 | 16.07 | 2.95 | 16.07 | 2.95 |
| 1125 | 57 (13.9) | 29.59 | 1.97 | 28.40 | 2.17 | 27.13 | 2.40 | 25.78 | 2.66 | 24.30 | 2.96 | 22.67 | 2.96 | 22.67 | 2.96 | 22.67 | 2.96 | 22.67 | 2.96 |
| | 62 (16.7) | 29.65 | 1.97 | 28.45 | 2.17 | 27.18 | 2.40 | 25.83 | 2.66 | 24.34 | 2.96 | 22.71 | 2.96 | 22.71 | 2.96 | 22.71 | 2.96 | 22.71 | 2.96 |
| | 63 (17.2) | 29.89 | 1.97 | 23.70 | 2.17 | 26.89 | 2.40 | 25.26 | 2.66 | 23.52 | 2.95 | 19.77 | 2.95 | 19.77 | 2.95 | 19.77 | 2.95 | 19.77 | 2.95 |
| | 67 (19.4) | 32.31 | 1.98 | 24.86 | 2.19 | 30.72 | 2.42 | 27.34 | 2.67 | 25.48 | 2.97 | 20.93 | 2.97 | 20.93 | 2.97 | 20.93 | 2.97 | 20.93 | 2.97 |
| | 72 (22.2) | 35.63 | 2.01 | 19.78 | 2.21 | 32.06 | 2.44 | 30.14 | 2.70 | 28.08 | 2.99 | 16.08 | 2.99 | 16.08 | 2.99 | 16.08 | 2.99 | 16.08 | 2.99 |

*At 75°F (23.9°C) entering dry bulb—Tennessee Valley Authority [TVA] rating conditions; all others at 80°F (26.7°C) entering dry bulb. See Legend and Notes.

30 Heating Extended Performance Table -10-60 (-23.3-15.6°C)

| INDOOR AIR | | OUTDOOR COIL ENTERING AIR TEMPERATURES deg F (deg C) | | | | | | | | | | | | | | | | | | | | | | | |
|------------|------|--|--------------|-------|----------------|--------------|-------|----------------|--------------|-------|----------------|--------------|-------|----------------|--------------|-------|----------------|--------------|-------|----------------|--------------|-------|----------------|--------------|-------|
| EDB | CFM | -10 (-23.3) | | | 0 (-17.8) | | | 10 (-12.2) | | | 20 (-6.7) | | | 30 (-1.1) | | | 40 (4.4) | | | 50 (10) | | | 60 (15.6) | | |
| | | Capacity MBtuh | Total Sys kW | Integ | Capacity MBtuh | Total Sys kW | Integ | Capacity MBtuh | Total Sys kW | Integ | Capacity MBtuh | Total Sys kW | Integ | Capacity MBtuh | Total Sys kW | Integ | Capacity MBtuh | Total Sys kW | Integ | Capacity MBtuh | Total Sys kW | Integ | Capacity MBtuh | Total Sys kW | Integ |
| 65 (18.3) | 875 | 9.56 | 8.79 | 1.94 | 12.51 | 11.51 | 2.01 | 16.03 | 14.71 | 2.09 | 19.18 | 17.39 | 2.16 | 22.61 | 19.81 | 2.23 | 26.50 | 26.50 | 2.32 | 31.02 | 31.02 | 2.44 | 36.42 | 36.42 | 2.60 |
| | 1000 | 9.74 | 8.96 | 1.96 | 12.71 | 11.70 | 2.02 | 16.27 | 14.93 | 2.09 | 19.37 | 17.57 | 2.15 | 22.86 | 20.03 | 2.22 | 28.81 | 28.81 | 2.30 | 31.42 | 31.42 | 2.41 | 36.91 | 36.91 | 2.56 |
| | 1125 | 9.89 | 9.10 | 1.98 | 12.89 | 11.86 | 2.04 | 16.43 | 15.08 | 2.10 | 19.55 | 17.73 | 2.15 | 23.07 | 20.21 | 2.21 | 27.06 | 27.06 | 2.29 | 31.72 | 31.72 | 2.39 | 37.19 | 37.19 | 2.54 |
| 70 (21.1) | 875 | 9.13 | 8.40 | 2.02 | 12.12 | 11.15 | 2.10 | 15.35 | 14.09 | 2.17 | 18.92 | 17.16 | 2.26 | 22.31 | 19.55 | 2.34 | 26.15 | 26.15 | 2.43 | 30.55 | 30.55 | 2.55 | 35.85 | 35.85 | 2.71 |
| | 1000 | 9.31 | 8.57 | 2.04 | 12.32 | 11.34 | 2.11 | 15.60 | 14.31 | 2.17 | 19.13 | 17.35 | 2.25 | 22.56 | 19.77 | 2.32 | 26.45 | 26.45 | 2.40 | 30.95 | 30.95 | 2.51 | 36.34 | 36.34 | 2.67 |
| | 1125 | 9.47 | 8.72 | 2.06 | 12.50 | 11.51 | 2.12 | 15.85 | 14.55 | 2.18 | 19.31 | 17.51 | 2.25 | 22.77 | 19.95 | 2.31 | 26.70 | 26.70 | 2.39 | 31.25 | 31.25 | 2.50 | 36.67 | 36.67 | 2.66 |
| 75 (23.9) | 875 | 8.67 | 7.98 | 2.11 | 11.69 | 10.76 | 2.19 | 14.93 | 13.70 | 2.27 | 18.68 | 16.94 | 2.37 | 22.01 | 19.29 | 2.45 | 25.79 | 25.79 | 2.54 | 30.10 | 30.10 | 2.67 | 35.28 | 35.28 | 2.83 |
| | 1000 | 8.85 | 8.14 | 2.12 | 11.90 | 10.95 | 2.20 | 15.16 | 13.92 | 2.27 | 18.88 | 17.12 | 2.36 | 22.25 | 19.50 | 2.43 | 26.09 | 26.09 | 2.51 | 30.49 | 30.49 | 2.63 | 35.76 | 35.76 | 2.78 |
| | 1125 | 9.01 | 8.29 | 2.15 | 12.08 | 11.12 | 2.21 | 15.36 | 14.10 | 2.28 | 19.05 | 17.27 | 2.36 | 22.46 | 19.68 | 2.42 | 26.33 | 26.33 | 2.50 | 30.79 | 30.79 | 2.61 | 36.10 | 36.10 | 2.77 |

PERFORMANCE DATA (CONT)

36 Cooling Extended Performance Table

| EVAPORATOR AIR | | CONDENSER ENTERING AIR TEMPERATURES deg F (deg C) | | | | | | | | | | | | | | | | | |
|----------------|--------------|---|-------|--------------|----------------|-------|--------------|----------------|-------|--------------|----------------|-------|--------------|----------------|-------|--------------|----------------|-------|--------------|
| CFM | EWB | 75 (23.9) | | | 85 (29.4) | | | 95 (35) | | | 105 (40.6) | | | 115 (46.1) | | | 125 (51.7) | | |
| | | Capacity MBtuh | | Total Sys kW | Capacity MBtuh | | Total Sys kW | Capacity MBtuh | | Total Sys kW | Capacity MBtuh | | Total Sys kW | Capacity MBtuh | | Total Sys kW | Capacity MBtuh | | Total Sys kW |
| | | Total | Sens | Total | Sens | Total | Sens | Total | Sens | Total | Sens | Total | Sens | Total | Sens | Total | Sens | Total | Sens |
| 1050 | 57 (13.9) | 33.80 | 33.80 | 2.35 | 32.51 | 32.51 | 2.62 | 31.13 | 31.13 | 2.92 | 29.64 | 29.64 | 3.26 | 28.00 | 28.00 | 3.65 | 26.21 | 26.21 | 4.10 |
| | 62 (16.7) | 35.12 | 31.40 | 2.36 | 30.56 | 30.56 | 2.62 | 31.82 | 29.63 | 2.92 | 28.60 | 28.60 | 3.26 | 28.11 | 28.06 | 3.65 | 26.26 | 26.26 | 4.10 |
| | 63 (17.2) | 35.63 | 25.64 | 2.36 | 33.98 | 24.84 | 2.63 | 32.23 | 24.00 | 2.93 | 23.10 | 23.10 | 3.26 | 28.32 | 22.12 | 3.65 | 26.12 | 21.07 | 4.10 |
| | 67 (19.4) | 38.56 | 26.79 | 2.38 | 36.80 | 25.98 | 2.65 | 34.93 | 25.15 | 2.95 | 24.26 | 24.26 | 3.28 | 30.76 | 23.29 | 3.67 | 28.43 | 22.24 | 4.11 |
| | 72 (22.2) | 42.38 | 22.02 | 2.40 | 40.45 | 21.27 | 2.68 | 38.42 | 20.46 | 2.98 | 19.60 | 19.60 | 3.31 | 33.88 | 18.68 | 3.70 | 31.34 | 17.68 | 4.14 |
| | 57 (13.9) | 35.46 | 35.46 | 2.39 | 34.08 | 34.08 | 2.66 | 32.59 | 32.59 | 2.96 | 30.99 | 30.99 | 3.30 | 29.24 | 29.24 | 3.69 | 27.32 | 27.32 | 4.13 |
| | 62 (16.7) | 36.21 | 33.75 | 2.39 | 34.54 | 32.85 | 2.66 | 32.81 | 31.79 | 2.96 | 31.05 | 31.05 | 3.30 | 29.29 | 29.29 | 3.69 | 27.37 | 27.37 | 4.13 |
| 1200 | 63 (17.2) | 36.62 | 27.38 | 2.39 | 34.89 | 26.53 | 2.66 | 33.05 | 25.66 | 2.96 | 24.72 | 24.72 | 3.30 | 28.96 | 23.70 | 3.68 | 26.68 | 22.59 | 4.13 |
| | 67 (19.4) | 39.61 | 28.66 | 2.41 | 37.76 | 27.82 | 2.69 | 35.80 | 26.95 | 2.98 | 26.01 | 26.01 | 3.32 | 31.44 | 25.00 | 3.71 | 29.01 | 23.90 | 4.15 |
| | 72 (22.2) | 43.49 | 23.23 | 2.44 | 41.47 | 22.43 | 2.72 | 39.34 | 21.59 | 3.02 | 20.70 | 20.70 | 3.35 | 34.60 | 19.74 | 3.74 | 31.95 | 18.70 | 4.17 |
| | 57 (13.9) | 36.89 | 36.89 | 2.43 | 35.42 | 35.42 | 2.70 | 33.84 | 33.84 | 3.00 | 32.14 | 32.14 | 3.34 | 30.28 | 30.28 | 3.72 | 28.26 | 28.26 | 4.17 |
| | 62 (16.7) | 37.18 | 35.89 | 2.43 | 35.49 | 35.49 | 2.70 | 33.90 | 33.90 | 3.00 | 32.19 | 32.19 | 3.34 | 30.33 | 30.33 | 3.72 | 28.31 | 28.31 | 4.17 |
| | 63 (17.2) | 37.42 | 29.04 | 2.43 | 35.62 | 28.17 | 2.70 | 33.71 | 27.26 | 2.99 | 26.28 | 26.28 | 3.33 | 29.48 | 25.20 | 3.72 | 27.14 | 24.02 | 4.16 |
| | 67 (19.4) | 40.44 | 30.46 | 2.45 | 38.52 | 29.60 | 2.72 | 36.49 | 28.69 | 3.02 | 27.70 | 27.70 | 3.36 | 31.98 | 26.64 | 3.74 | 29.48 | 25.47 | 4.18 |
| 72 (22.2) | 44.37 | 24.36 | 2.48 | 42.29 | 23.54 | 2.75 | 40.06 | 22.67 | 3.05 | 21.74 | 21.74 | 3.39 | 35.15 | 20.74 | 3.77 | 32.42 | 19.67 | 4.21 | |

*At 75°F (23.9 °C) entering dry bulb—Tennessee Valley Authority [TVA] rating conditions; all others at 80°F (26.7 °C) entering dry bulb. See Legend and Notes.

36 Heating Extended Performance Table -10-60 (-23.3-15.6 °C)

| INDOOR AIR | | OUTDOOR COIL ENTERING AIR TEMPERATURES deg F (deg C) | | | | | | | | | | | | | | | | | | | | | | | |
|--------------|------|--|-------|--------------|----------------|-------|--------------|----------------|-------|--------------|----------------|-------|--------------|----------------|-------|--------------|----------------|-------|--------------|----------------|-------|--------------|----------------|-------|--------------|
| EDB | CFM | -10 (-23.3) | | | 0 (-17.8) | | | 10 (-12.2) | | | 20 (-6.7) | | | 30 (-1.1) | | | 40 (4.4) | | | 50 (10) | | | 60 (15.6) | | |
| | | Capacity MBtuh | | Total Sys kW | Capacity MBtuh | | Total Sys kW | Capacity MBtuh | | Total Sys kW | Capacity MBtuh | | Total Sys kW | Capacity MBtuh | | Total Sys kW | Capacity MBtuh | | Total Sys kW | Capacity MBtuh | | Total Sys kW | Capacity MBtuh | | Total Sys kW |
| | | Total | Integ | Total | Integ | Total | Integ | Total | Integ | Total | Integ | Total | Integ | Total | Integ | Total | Integ | Total | Integ | Total | Integ | Total | Integ | | |
| 65 (18.3) | 1050 | 12.06 | 11.10 | 2.28 | 15.94 | 14.11 | 2.37 | 19.31 | 17.73 | 2.48 | 22.99 | 20.85 | 2.57 | 27.20 | 23.83 | 2.67 | 32.01 | 27.9 | 2.79 | 37.62 | 32.96 | 2.96 | 44.15 | 44.15 | |
| | 1200 | 12.24 | 11.26 | 2.28 | 15.55 | 14.31 | 2.37 | 19.49 | 17.89 | 2.46 | 23.21 | 21.05 | 2.54 | 27.49 | 24.09 | 2.63 | 32.36 | 27.5 | 2.92 | 38.06 | 33.06 | 2.92 | 43.75 | 43.75 | |
| | 1350 | 12.40 | 11.41 | 2.29 | 15.73 | 14.47 | 2.37 | 19.66 | 18.05 | 2.46 | 23.40 | 21.22 | 2.53 | 27.72 | 24.29 | 2.62 | 32.62 | 27.3 | 2.88 | 38.08 | 33.08 | 2.88 | 42.98 | 42.98 | |
| 70 (21.1) | 1050 | 11.60 | 10.67 | 2.40 | 14.89 | 13.70 | 2.49 | 19.02 | 17.45 | 2.61 | 22.66 | 20.55 | 2.69 | 26.81 | 23.49 | 2.80 | 31.55 | 29.3 | 2.93 | 37.02 | 32.02 | 3.10 | 43.57 | 43.57 | |
| | 1200 | 11.79 | 10.84 | 2.40 | 15.10 | 13.89 | 2.49 | 19.22 | 17.64 | 2.59 | 22.88 | 20.75 | 2.67 | 27.09 | 23.74 | 2.76 | 31.91 | 29.8 | 2.88 | 37.47 | 32.47 | 3.05 | 43.39 | 43.39 | |
| | 1350 | 11.95 | 10.99 | 2.41 | 15.28 | 14.06 | 2.49 | 19.39 | 17.80 | 2.59 | 23.08 | 20.93 | 2.66 | 27.33 | 23.94 | 2.74 | 32.17 | 29.6 | 2.86 | 37.72 | 32.72 | 3.02 | 42.75 | 42.75 | |
| 75 (23.9) | 1050 | 11.10 | 10.21 | 2.52 | 14.41 | 13.26 | 2.62 | 18.18 | 16.69 | 2.72 | 22.35 | 20.27 | 2.83 | 26.42 | 23.15 | 2.94 | 31.08 | 28.3 | 3.07 | 36.44 | 31.44 | 3.24 | 42.87 | 42.87 | |
| | 1200 | 11.29 | 10.38 | 2.53 | 14.62 | 13.46 | 2.62 | 18.52 | 17.00 | 2.71 | 22.56 | 20.46 | 2.81 | 26.70 | 23.40 | 2.90 | 31.43 | 28.6 | 3.02 | 36.87 | 31.8 | 3.18 | 42.98 | 42.98 | |
| | 1350 | 11.45 | 10.53 | 2.54 | 14.81 | 13.62 | 2.62 | 18.95 | 17.40 | 2.71 | 22.75 | 20.64 | 2.79 | 26.93 | 23.60 | 2.88 | 31.71 | 29.9 | 3.17 | 37.19 | 32.19 | 3.17 | 42.46 | 42.46 | |

PERFORMANCE DATA (CONT)

42 Cooling Extended Performance Table

| EVAPORATOR AIR | | CONDENSER ENTERING AIR TEMPERATURES deg F (deg C) | | | | | | | | | | | | | | | | | |
|----------------|-----------|---|-------|--------------|----------------|-------|--------------|----------------|-------|--------------|----------------|-------|--------------|----------------|-------|--------------|----------------|-------|--------------|
| CFM | EWB | 75 (23.9) | | | 85 (29.4) | | | 95 (35) | | | 105 (40.6) | | | 115 (46.1) | | | 125 (51.7) | | |
| | | Capacity MBtuh | | Total Sys kW | Capacity MBtuh | | Total Sys kW | Capacity MBtuh | | Total Sys kW | Capacity MBtuh | | Total Sys kW | Capacity MBtuh | | Total Sys kW | Capacity MBtuh | | Total Sys kW |
| | | Total | Sens | | Total | Sens | | Total | Sens | | Total | Sens | | Total | Sens | | Total | Sens | |
| 1225 | 57 (13.9) | 38.52 | 38.52 | 2.64 | 36.98 | 36.98 | 2.93 | 35.30 | 35.30 | 3.27 | 33.49 | 33.49 | 3.66 | 31.53 | 31.53 | 4.11 | 29.35 | 29.35 | 4.64 |
| | 62 (16.7) | 40.25 | 36.53 | 2.66 | 38.38 | 35.40 | 2.95 | 36.38 | 34.18 | 3.28 | 34.25 | 32.85 | 3.67 | 31.99 | 31.37 | 4.12 | 29.51 | 29.51 | 4.64 |
| | 63 (17.2) | 40.42 | 29.59 | 2.66 | 38.51 | 28.53 | 2.95 | 36.47 | 27.40 | 3.28 | 34.29 | 26.19 | 3.67 | 31.96 | 24.88 | 4.12 | 29.43 | 23.45 | 4.64 |
| | 67 (19.4) | 43.85 | 31.00 | 2.69 | 41.76 | 29.93 | 2.98 | 39.56 | 28.79 | 3.32 | 37.21 | 27.56 | 3.71 | 34.68 | 26.23 | 4.17 | 31.95 | 24.78 | 4.70 |
| | 72 (22.2) | 47.65 | 25.61 | 2.73 | 45.34 | 24.58 | 3.02 | 42.92 | 23.50 | 3.37 | 40.32 | 22.34 | 3.77 | 37.55 | 21.10 | 4.23 | 34.58 | 19.76 | 4.76 |
| | 57 (13.9) | 40.25 | 40.25 | 2.70 | 38.58 | 38.58 | 2.99 | 36.77 | 36.77 | 3.33 | 34.83 | 34.83 | 3.72 | 32.71 | 32.71 | 4.18 | 30.39 | 30.39 | 4.71 |
| | 62 (16.7) | 41.40 | 39.06 | 2.71 | 39.43 | 37.83 | 3.00 | 37.36 | 36.48 | 3.33 | 35.17 | 34.96 | 3.73 | 32.82 | 32.82 | 4.18 | 30.43 | 30.43 | 4.71 |
| 1400 | 63 (17.2) | 41.51 | 31.29 | 2.71 | 39.49 | 30.16 | 3.00 | 37.35 | 28.97 | 3.33 | 35.07 | 27.69 | 3.72 | 32.62 | 26.30 | 4.17 | 29.99 | 24.80 | 4.70 |
| | 67 (19.4) | 45.01 | 32.87 | 2.74 | 42.81 | 31.72 | 3.04 | 40.50 | 30.50 | 3.37 | 38.03 | 29.20 | 3.77 | 35.38 | 27.79 | 4.23 | 32.54 | 26.26 | 4.76 |
| | 72 (22.2) | 48.85 | 26.74 | 2.78 | 46.43 | 25.66 | 3.08 | 43.87 | 24.51 | 3.42 | 41.16 | 23.30 | 3.83 | 38.26 | 21.99 | 4.29 | 35.16 | 20.59 | 4.82 |
| | 57 (13.9) | 41.72 | 41.72 | 2.75 | 39.93 | 39.93 | 3.05 | 38.01 | 38.01 | 3.39 | 35.94 | 35.94 | 3.78 | 33.69 | 33.69 | 4.24 | 31.24 | 31.24 | 4.77 |
| | 62 (16.7) | 42.39 | 41.37 | 2.76 | 40.36 | 39.99 | 3.05 | 38.18 | 38.18 | 3.39 | 36.02 | 36.02 | 3.78 | 33.74 | 33.74 | 4.24 | 31.28 | 31.28 | 4.77 |
| | 63 (17.2) | 42.38 | 32.88 | 2.76 | 40.28 | 31.70 | 3.05 | 38.04 | 30.44 | 3.38 | 35.68 | 29.10 | 3.77 | 33.14 | 27.65 | 4.23 | 30.42 | 26.06 | 4.75 |
| | 67 (19.4) | 45.94 | 34.61 | 2.79 | 43.65 | 33.40 | 3.09 | 41.24 | 32.12 | 3.43 | 38.67 | 30.74 | 3.83 | 35.92 | 29.27 | 4.28 | 32.99 | 27.66 | 4.81 |
| 72 (22.2) | 49.80 | 27.78 | 2.84 | 47.28 | 26.65 | 3.14 | 44.62 | 25.45 | 3.48 | 41.80 | 24.18 | 3.88 | 38.81 | 22.81 | 4.35 | 35.62 | 21.35 | 4.88 | |

*At 75°F (23.9°C) entering dry bulb—Tennessee Valley Authority [TVA] rating conditions; all others at 80°F (26.7°C) entering dry bulb. See Legend and Notes.

42 Heating Extended Performance Table -10-60 (-23.3-15.6°C)

| INDOOR AIR | | OUTDOOR COIL ENTERING AIR TEMPERATURES deg F (deg C) | | | | | | | | | | | | | | | | | | | | | | | |
|------------|------|--|-------|--------------|----------------|-------|--------------|----------------|-------|--------------|----------------|-------|--------------|----------------|-------|--------------|----------------|-------|--------------|----------------|-------|--------------|----------------|-------|--------------|
| EDB | CFM | -10 (-23.3) | | | 0 (-17.8) | | | 10 (-12.2) | | | 20 (-6.7) | | | 30 (-1.1) | | | 40 (4.4) | | | 50 (10) | | | 60 (15.6) | | |
| | | Capacity MBtuh | | Total Sys kW | Capacity MBtuh | | Total Sys kW | Capacity MBtuh | | Total Sys kW | Capacity MBtuh | | Total Sys kW | Capacity MBtuh | | Total Sys kW | Capacity MBtuh | | Total Sys kW | Capacity MBtuh | | Total Sys kW | Capacity MBtuh | | Total Sys kW |
| | | Total | Integ | | Total | Integ | | Total | Integ | | Total | Integ | | Total | Integ | | Total | Integ | | Total | Integ | | Total | Integ | |
| 65 (18.3) | 1225 | 13.77 | 12.67 | 2.42 | 17.68 | 16.26 | 2.58 | 21.89 | 20.09 | 2.72 | 25.94 | 23.53 | 2.83 | 30.55 | 26.77 | 2.94 | 35.85 | 31.08 | 3.08 | 42.16 | 37.29 | 3.29 | 48.46 | 43.46 | |
| | 1400 | 13.95 | 12.63 | 2.44 | 17.89 | 16.46 | 2.59 | 22.07 | 20.26 | 2.72 | 26.18 | 23.74 | 2.82 | 30.86 | 27.04 | 2.92 | 36.22 | 31.06 | 3.06 | 42.20 | 37.24 | 3.24 | 47.82 | 42.82 | |
| | 1575 | 14.11 | 12.98 | 2.46 | 18.12 | 16.68 | 2.61 | 22.25 | 20.42 | 2.73 | 26.38 | 23.93 | 2.82 | 31.11 | 27.26 | 2.92 | 36.53 | 31.07 | 3.07 | 41.84 | 37.24 | 3.24 | 47.22 | 42.22 | |
| 70 (21.1) | 1225 | 13.46 | 12.38 | 2.56 | 17.32 | 15.93 | 2.72 | 21.69 | 19.91 | 2.86 | 25.65 | 23.26 | 2.96 | 30.15 | 26.42 | 3.08 | 35.34 | 31.22 | 3.22 | 41.53 | 37.24 | 3.44 | 48.06 | 43.06 | |
| | 1400 | 13.65 | 12.56 | 2.57 | 17.54 | 16.14 | 2.72 | 21.88 | 20.08 | 2.86 | 25.89 | 23.48 | 2.95 | 30.46 | 26.69 | 3.06 | 35.70 | 31.50 | 3.20 | 41.84 | 37.24 | 3.44 | 47.53 | 42.53 | |
| | 1575 | 13.82 | 12.72 | 2.59 | 17.73 | 16.32 | 2.74 | 22.04 | 20.23 | 2.86 | 26.11 | 23.68 | 2.95 | 30.72 | 26.91 | 3.05 | 36.01 | 31.20 | 3.20 | 41.57 | 37.24 | 3.39 | 46.99 | 41.99 | |
| 75 (23.9) | 1225 | 13.07 | 12.03 | 2.69 | 16.92 | 15.57 | 2.85 | 21.46 | 19.70 | 3.00 | 25.36 | 23.00 | 3.11 | 29.77 | 26.09 | 3.22 | 34.82 | 30.42 | 3.37 | 40.89 | 36.00 | 3.60 | 47.64 | 42.64 | |
| | 1400 | 13.27 | 12.21 | 2.71 | 17.15 | 15.78 | 2.86 | 21.67 | 19.89 | 3.00 | 25.60 | 23.21 | 3.09 | 30.06 | 26.34 | 3.20 | 35.19 | 30.34 | 3.34 | 41.34 | 36.56 | 3.54 | 47.18 | 42.18 | |
| | 1575 | 13.45 | 12.38 | 2.73 | 17.36 | 15.97 | 2.88 | 21.83 | 20.04 | 3.01 | 25.80 | 23.40 | 3.09 | 30.32 | 26.56 | 3.19 | 35.47 | 30.34 | 3.34 | 41.27 | 36.54 | 3.54 | 46.71 | 41.71 | |

PERFORMANCE DATA (CONT)

48 Cooling Extended Performance Table

| EVAPORATOR AIR | | CONDENSER ENTERING AIR TEMPERATURES deg F (deg C) | | | | | | | | | | | | | | | | | |
|----------------|--------------|---|-------|--------------|----------------|-------|--------------|----------------|-------|--------------|----------------|-------|--------------|----------------|-------|--------------|----------------|-------|--------------|
| CFM | EWB | 75 (23.9) | | | 85 (29.4) | | | 95 (35) | | | 105 (40.6) | | | 115 (46.1) | | | 125 (51.7) | | |
| | | Capacity MBtuh | | Total Sys kW | Capacity MBtuh | | Total Sys kW | Capacity MBtuh | | Total Sys kW | Capacity MBtuh | | Total Sys kW | Capacity MBtuh | | Total Sys kW | Capacity MBtuh | | Total Sys kW |
| | | Total | Sens | Total | Sens | Total | Sens | Total | Sens | Total | Sens | Total | Sens | Total | Sens | Total | Sens | Total | Sens |
| 1400 | 57 (13.9) | 44.75 | 44.75 | 3.06 | 42.98 | 42.98 | 3.39 | 41.06 | 41.06 | 3.77 | 39.00 | 39.00 | 4.20 | 36.79 | 36.79 | 4.67 | 34.42 | 34.42 | 5.18 |
| | 62 (16.7) | 46.12 | 41.54 | 3.07 | 43.97 | 40.35 | 3.40 | 41.69 | 39.04 | 3.78 | 39.29 | 37.55 | 4.20 | 36.86 | 36.86 | 4.67 | 34.48 | 34.48 | 5.18 |
| | 63 (17.2) | 46.70 | 33.68 | 3.07 | 44.47 | 32.60 | 3.41 | 42.08 | 31.45 | 3.78 | 39.54 | 30.23 | 4.20 | 36.87 | 28.94 | 4.67 | 34.05 | 27.58 | 5.18 |
| | 67 (19.4) | 50.55 | 35.24 | 3.10 | 48.13 | 34.15 | 3.43 | 45.54 | 32.98 | 3.81 | 42.81 | 31.75 | 4.23 | 39.93 | 30.45 | 4.70 | 36.89 | 29.07 | 5.21 |
| | 72 (22.2) | 55.52 | 28.74 | 3.13 | 52.82 | 27.67 | 3.47 | 49.97 | 26.55 | 3.84 | 46.97 | 25.36 | 4.26 | 43.81 | 24.12 | 4.73 | 40.47 | 22.80 | 5.24 |
| | 57 (13.9) | 46.77 | 46.77 | 3.13 | 44.87 | 44.87 | 3.47 | 42.79 | 42.79 | 3.85 | 40.57 | 40.57 | 4.27 | 38.20 | 38.20 | 4.74 | 35.66 | 35.66 | 5.25 |
| | 62 (16.7) | 47.44 | 44.50 | 3.14 | 45.22 | 43.17 | 3.47 | 42.89 | 42.89 | 3.85 | 40.63 | 40.63 | 4.27 | 38.26 | 38.26 | 4.74 | 35.71 | 35.71 | 5.25 |
| 1600 | 63 (17.2) | 47.85 | 35.90 | 3.14 | 45.50 | 34.77 | 3.47 | 42.99 | 33.55 | 3.85 | 40.33 | 32.27 | 4.27 | 37.54 | 30.91 | 4.73 | 34.62 | 29.45 | 5.24 |
| | 67 (19.4) | 51.78 | 37.65 | 3.17 | 49.22 | 36.50 | 3.50 | 46.50 | 35.26 | 3.88 | 43.64 | 33.97 | 4.30 | 40.64 | 32.61 | 4.76 | 37.48 | 31.13 | 5.27 |
| | 72 (22.2) | 56.83 | 30.24 | 3.20 | 53.99 | 29.12 | 3.53 | 51.00 | 27.94 | 3.91 | 47.86 | 26.71 | 4.33 | 44.56 | 25.40 | 4.80 | 41.08 | 24.03 | 5.30 |
| | 57 (13.9) | 48.51 | 48.51 | 3.20 | 46.46 | 46.46 | 3.54 | 44.24 | 44.24 | 3.92 | 41.88 | 41.88 | 4.34 | 39.36 | 39.36 | 4.81 | 36.67 | 36.67 | 5.32 |
| | 62 (16.7) | 48.63 | 48.63 | 3.20 | 46.54 | 46.54 | 3.54 | 44.31 | 44.31 | 3.92 | 41.95 | 41.95 | 4.34 | 39.42 | 39.42 | 4.81 | 36.72 | 36.72 | 5.32 |
| | 63 (17.2) | 48.76 | 38.03 | 3.20 | 46.31 | 36.85 | 3.54 | 43.69 | 35.57 | 3.91 | 40.94 | 34.21 | 4.33 | 38.07 | 32.76 | 4.80 | 35.07 | 31.19 | 5.30 |
| | 67 (19.4) | 52.73 | 39.96 | 3.23 | 50.06 | 38.75 | 3.56 | 47.24 | 37.47 | 3.94 | 44.28 | 36.10 | 4.36 | 41.18 | 34.64 | 4.83 | 37.93 | 33.06 | 5.33 |
| 72 (22.2) | 57.85 | 31.65 | 3.26 | 54.90 | 30.49 | 3.60 | 51.79 | 29.26 | 3.97 | 48.53 | 27.98 | 4.39 | 45.11 | 26.62 | 4.86 | 41.53 | 25.19 | 5.36 | |

*At 75°F (23.9 °C) entering dry bulb—Tennessee Valley Authority [TVA] rating conditions; all others at 80°F (26.7 °C) entering dry bulb. See Legend and Notes.

48 Heating Extended Performance Table -10-60 (-23.3-15.6 °C)

| INDOOR AIR | | OUTDOOR COIL ENTERING AIR TEMPERATURES deg F (deg C) | | | | | | | | | | | | | | | | | | | | | | | |
|--------------|------|--|-------|--------------|----------------|-------|--------------|----------------|-------|--------------|----------------|-------|--------------|----------------|-------|--------------|----------------|-------|--------------|----------------|-------|--------------|----------------|-------|--------------|
| EDB | CFM | -10 (-23.3) | | | 0 (-17.8) | | | 10 (-12.2) | | | 20 (-6.7) | | | 30 (-1.1) | | | 40 (4.4) | | | 50 (10) | | | 60 (15.6) | | |
| | | Capacity MBtuh | | Total Sys kW | Capacity MBtuh | | Total Sys kW | Capacity MBtuh | | Total Sys kW | Capacity MBtuh | | Total Sys kW | Capacity MBtuh | | Total Sys kW | Capacity MBtuh | | Total Sys kW | Capacity MBtuh | | Total Sys kW | Capacity MBtuh | | Total Sys kW |
| | | Total | Integ | Total | Integ | Total | Integ | Total | Integ | Total | Integ | Total | Integ | Total | Integ | Total | Integ | Total | Integ | Total | Integ | Total | Integ | | |
| 65 (18.3) | 1400 | 15.24 | 14.02 | 3.00 | 20.15 | 18.54 | 3.09 | 25.29 | 23.21 | 3.21 | 29.94 | 27.15 | 3.32 | 35.20 | 30.84 | 3.45 | 41.16 | 41.16 | 3.62 | 48.10 | 48.10 | 3.83 | 54.59 | 54.59 | 4.07 |
| | 1600 | 15.50 | 14.26 | 3.04 | 20.44 | 18.80 | 3.12 | 25.55 | 23.45 | 3.23 | 30.25 | 27.43 | 3.33 | 35.57 | 31.17 | 3.45 | 41.64 | 41.64 | 3.63 | 47.73 | 47.73 | 3.81 | 53.60 | 53.60 | 4.04 |
| | 1800 | 15.74 | 14.48 | 3.09 | 20.70 | 19.05 | 3.16 | 25.78 | 23.66 | 3.26 | 30.52 | 27.68 | 3.35 | 35.88 | 31.43 | 3.47 | 41.86 | 41.86 | 3.63 | 47.20 | 47.20 | 3.82 | 52.65 | 52.65 | 4.03 |
| 70 (21.1) | 1400 | 14.75 | 13.57 | 3.12 | 19.66 | 18.09 | 3.22 | 25.02 | 22.96 | 3.36 | 29.60 | 26.84 | 3.47 | 34.73 | 30.43 | 3.61 | 40.57 | 40.57 | 3.79 | 47.52 | 47.52 | 4.02 | 54.22 | 54.22 | 4.26 |
| | 1600 | 15.01 | 13.81 | 3.16 | 19.94 | 18.34 | 3.25 | 25.26 | 23.19 | 3.37 | 29.91 | 27.12 | 3.48 | 35.11 | 30.76 | 3.61 | 41.02 | 41.02 | 3.78 | 47.42 | 47.42 | 3.98 | 53.38 | 53.38 | 4.23 |
| | 1800 | 15.27 | 14.04 | 3.21 | 20.24 | 18.62 | 3.29 | 25.51 | 23.41 | 3.40 | 30.18 | 27.37 | 3.50 | 35.42 | 31.04 | 3.63 | 41.43 | 41.43 | 3.80 | 46.98 | 46.98 | 3.99 | 52.55 | 52.55 | 4.22 |
| 75 (23.9) | 1400 | 14.22 | 13.08 | 3.25 | 19.13 | 17.60 | 3.36 | 24.68 | 22.65 | 3.51 | 29.23 | 26.51 | 3.64 | 34.26 | 30.34 | 3.78 | 39.96 | 39.96 | 3.96 | 46.79 | 46.79 | 4.21 | 53.79 | 53.79 | 4.46 |
| | 1600 | 14.48 | 13.32 | 3.29 | 19.44 | 17.89 | 3.39 | 24.97 | 22.92 | 3.53 | 29.54 | 26.79 | 3.64 | 34.63 | 30.34 | 3.78 | 40.40 | 40.40 | 3.95 | 47.06 | 47.06 | 4.16 | 53.09 | 53.09 | 4.42 |
| | 1800 | 14.73 | 13.55 | 3.34 | 19.71 | 18.14 | 3.43 | 25.22 | 23.15 | 3.56 | 29.82 | 27.04 | 3.66 | 34.95 | 30.62 | 3.79 | 40.82 | 40.82 | 3.98 | 46.70 | 46.70 | 4.17 | 52.35 | 52.35 | 4.42 |

PERFORMANCE DATA (CONT)

60 Cooling Extended Performance Table

| EVAPORATOR AIR | | CONDENSER ENTERING AIR TEMPERATURES deg F (deg C) | | | | | | | | | | | | | | | | | |
|----------------|-----------|---|--------------|----------------|--------------|----------------|--------------|----------------|--------------|----------------|--------------|----------------|--------------|-------|-------|-------|-------|-------|------|
| CFM | EWB | 75 (23.9) | | 85 (29.4) | | 95 (35) | | 105 (40.6) | | 115 (46.1) | | 125 (51.7) | | | | | | | |
| | | Capacity MBtuh | Total Sys kW | Capacity MBtuh | Total Sys kW | Capacity MBtuh | Total Sys kW | Capacity MBtuh | Total Sys kW | Capacity MBtuh | Total Sys kW | Capacity MBtuh | Total Sys kW | | | | | | |
| | | Total | Sens | Total | Sens | Total | Sens | Total | Sens | Total | Sens | Total | Sens | | | | | | |
| 1750 | 57 (13.9) | 56.58 | 56.58 | 3.82 | 54.25 | 51.74 | 51.74 | 4.69 | 49.03 | 46.02 | 46.02 | 5.20 | 42.74 | 42.74 | 5.80 | 42.74 | 42.74 | 6.47 | |
| | 62 (16.7) | 58.15 | 51.34 | 3.84 | 49.87 | 48.23 | 48.23 | 4.69 | 49.14 | 46.10 | 46.10 | 5.21 | 42.80 | 42.80 | 5.80 | 42.80 | 42.80 | 6.47 | |
| | 63 (17.2) | 58.96 | 41.68 | 3.85 | 40.35 | 52.93 | 38.94 | 4.70 | 49.57 | 37.43 | 35.80 | 5.21 | 42.09 | 34.04 | 5.79 | 42.09 | 34.04 | 6.46 | |
| | 67 (19.4) | 63.58 | 43.48 | 3.90 | 60.40 | 57.00 | 40.70 | 4.75 | 53.35 | 39.18 | 37.52 | 5.26 | 45.21 | 35.73 | 5.84 | 45.21 | 35.73 | 6.50 | |
| | 72 (22.2) | 69.81 | 35.09 | 3.96 | 66.25 | 62.44 | 32.52 | 4.82 | 58.39 | 31.04 | 29.43 | 5.33 | 49.34 | 27.71 | 5.90 | 49.34 | 27.71 | 6.55 | |
| | 57 (13.9) | 59.07 | 59.07 | 3.93 | 56.53 | 53.81 | 53.81 | 4.79 | 50.87 | 50.87 | 47.61 | 47.61 | 5.31 | 44.07 | 44.07 | 5.89 | 44.07 | 44.07 | 6.56 |
| | 62 (16.7) | 59.71 | 55.08 | 3.93 | 56.79 | 53.90 | 53.90 | 4.79 | 50.94 | 50.94 | 47.68 | 47.68 | 5.31 | 44.13 | 44.13 | 5.90 | 44.13 | 44.13 | 6.56 |
| 2000 | 63 (17.2) | 60.33 | 44.49 | 3.94 | 57.22 | 53.93 | 41.62 | 4.79 | 50.41 | 40.03 | 38.29 | 5.30 | 42.63 | 36.38 | 5.88 | 42.63 | 36.38 | 6.54 | |
| | 67 (19.4) | 64.95 | 46.50 | 3.99 | 61.60 | 58.02 | 43.59 | 4.84 | 54.20 | 41.98 | 40.22 | 5.35 | 45.71 | 38.29 | 5.93 | 45.71 | 38.29 | 6.58 | |
| | 72 (22.2) | 71.19 | 37.15 | 4.06 | 67.47 | 63.50 | 34.29 | 4.91 | 59.27 | 32.74 | 31.06 | 5.42 | 49.83 | 29.27 | 5.99 | 49.83 | 29.27 | 6.63 | |
| | 57 (13.9) | 61.14 | 61.14 | 4.03 | 58.43 | 55.52 | 55.52 | 4.89 | 52.36 | 52.36 | 48.89 | 48.89 | 5.40 | 45.23 | 45.23 | 5.99 | 45.23 | 45.23 | 6.65 |
| | 62 (16.7) | 61.25 | 61.25 | 4.03 | 58.52 | 55.60 | 55.60 | 4.89 | 52.43 | 52.43 | 48.95 | 48.95 | 5.40 | 45.28 | 45.28 | 5.99 | 45.28 | 45.28 | 6.65 |
| | 63 (17.2) | 61.37 | 47.18 | 4.03 | 58.11 | 54.69 | 44.17 | 4.88 | 51.04 | 42.48 | 40.61 | 5.38 | 43.03 | 38.53 | 5.96 | 43.03 | 38.53 | 6.62 | |
| | 67 (19.4) | 65.96 | 49.40 | 4.08 | 62.50 | 58.79 | 46.35 | 4.93 | 54.82 | 44.65 | 42.76 | 5.44 | 46.07 | 40.65 | 6.01 | 46.07 | 40.65 | 6.66 | |
| 72 (22.2) | 72.28 | 38.89 | 4.15 | 68.41 | 64.28 | 35.97 | 5.00 | 59.88 | 34.37 | 32.63 | 5.51 | 50.13 | 30.78 | 6.08 | 50.13 | 30.78 | 6.71 | | |

*At 75°F (23.9 °C) entering dry bulb—Tennessee Valley Authority (TVA) rating conditions; all others at 80°F (26.7 °C) entering dry bulb. See Legend and Notes.

60 Heating Extended Performance Table -10-60 (-23.3-15.6 °C)

| INDOOR AIR | | OUTDOOR COIL ENTERING AIR TEMPERATURES deg F (deg C) | | | | | | | | | | | | | | | | | | | | | | | |
|------------|------|--|--------------|----------------|--------------|----------------|--------------|----------------|--------------|----------------|--------------|----------------|--------------|----------------|--------------|----------------|--------------|-------|------|-------|-------|------|-------|-------|------|
| EDB | CFM | -10 (-23.3) | | 0 (-17.8) | | 10 (-12.2) | | 20 (-6.7) | | 30 (-1.1) | | 40 (4.4) | | 50 (10) | | 60 (15.6) | | | | | | | | | |
| | | Capacity MBtuh | Total Sys kW | Capacity MBtuh | Total Sys kW | Capacity MBtuh | Total Sys kW | Capacity MBtuh | Total Sys kW | Capacity MBtuh | Total Sys kW | Capacity MBtuh | Total Sys kW | Capacity MBtuh | Total Sys kW | Capacity MBtuh | Total Sys kW | | | | | | | | |
| | | Total | Integ | Total | Integ | Total | Integ | Total | Integ | Total | Integ | Total | Integ | Total | Integ | Total | Integ | | | | | | | | |
| 65 (18.3) | 1750 | 21.10 | 19.41 | 3.70 | 26.76 | 24.62 | 3.86 | 32.87 | 30.17 | 4.02 | 39.65 | 35.96 | 4.20 | 46.23 | 40.51 | 4.36 | 53.69 | 53.69 | 4.55 | 62.45 | 62.45 | 4.80 | 72.83 | 72.83 | 5.13 |
| | 2000 | 21.50 | 19.78 | 3.75 | 27.19 | 25.02 | 3.90 | 33.42 | 30.68 | 4.05 | 40.05 | 36.32 | 4.20 | 46.75 | 40.96 | 4.35 | 54.33 | 54.33 | 4.52 | 63.26 | 63.26 | 4.75 | 73.85 | 73.85 | 5.06 |
| | 2250 | 21.87 | 20.12 | 3.81 | 27.58 | 25.37 | 3.95 | 34.54 | 31.70 | 4.11 | 40.41 | 36.65 | 4.23 | 47.21 | 41.37 | 4.36 | 54.88 | 54.88 | 4.52 | 63.92 | 63.92 | 4.74 | 74.66 | 74.66 | 5.04 |
| 70 (21.1) | 1750 | 20.30 | 18.67 | 3.85 | 26.01 | 23.93 | 4.02 | 32.15 | 29.51 | 4.19 | 39.25 | 35.59 | 4.39 | 45.69 | 40.03 | 4.56 | 52.98 | 52.98 | 4.76 | 61.58 | 61.58 | 5.02 | 71.76 | 71.76 | 5.35 |
| | 2000 | 20.71 | 19.05 | 3.90 | 26.46 | 24.34 | 4.06 | 32.62 | 29.94 | 4.22 | 39.63 | 35.94 | 4.39 | 46.19 | 40.47 | 4.55 | 53.62 | 53.62 | 4.73 | 62.37 | 62.37 | 4.96 | 72.76 | 72.76 | 5.27 |
| | 2250 | 21.08 | 19.39 | 3.96 | 26.85 | 24.71 | 4.11 | 33.01 | 30.30 | 4.25 | 40.01 | 36.29 | 4.42 | 46.63 | 40.86 | 4.56 | 54.16 | 54.16 | 4.73 | 63.03 | 63.03 | 4.95 | 73.56 | 73.56 | 5.26 |
| 75 (23.9) | 1750 | 19.43 | 17.88 | 4.01 | 25.43 | 23.21 | 4.19 | 31.39 | 28.81 | 4.38 | 38.81 | 35.20 | 4.40 | 45.13 | 39.54 | 4.78 | 52.29 | 52.29 | 4.98 | 60.72 | 60.72 | 5.24 | 70.71 | 70.71 | 5.58 |
| | 2000 | 19.85 | 18.26 | 4.06 | 25.67 | 23.62 | 4.23 | 31.88 | 29.26 | 4.40 | 39.22 | 35.57 | 4.60 | 45.64 | 39.99 | 4.76 | 52.90 | 52.90 | 4.95 | 61.50 | 61.50 | 5.18 | 71.69 | 71.69 | 5.50 |
| | 2250 | 20.22 | 18.61 | 4.12 | 26.07 | 23.98 | 4.28 | 32.31 | 29.65 | 4.44 | 39.61 | 35.92 | 4.62 | 46.08 | 40.37 | 4.77 | 53.44 | 53.44 | 4.94 | 62.15 | 62.15 | 5.16 | 72.44 | 72.44 | 5.47 |

LEGEND

- BF — Bypass Factor
 - edb — Entering Dry-Bulb
 - Ewb — Entering Wet-Bulb
 - kw — Total Unit Power Input
 - SHC — Sensible Heat Capacity (1000 Btuh)
 - th — Total Capacity (1000 Btuh) (net)
 - Relative Humidity
- COOLING NOTES:**
1. Ratings are net; they account for the effects of the evaporator—fan motor power and heat.
 2. Direct interpolation is permissible. Do not extrapolate.
 3. The following formulas may be used:

Sensible capacity (Btuh)

$$t_{db} = t_{edb} - 1.10 \times CFM$$

$$t_{lwb} = \text{Wet-bulb temperature corresponding to enthalpy} - \text{air leaving evaporator coil } (t_{lwb})$$

$$h_{lwb} = \frac{\text{total capacity (Btuh)}}{4.5 \times CFM}$$

Where: h_{ewb} = Enthalpy of air entering evaporator coil
 4. The SHC is based on 80°F (26.6°C) edb temperature of air entering evaporator coil. Below 80°F (26.6°C) edb, subtract (corr factor x CFM) from SHC.

Above 80°F (26.6°C) edb, add (corr factor x CFM) to SHC.
 Correction Factor = 1.10 x (1 + BF) x (edb - 80).
 5. Integrated capacity is maximum (instantaneous) capacity less the effect of frost on the outdoor coil and the heat required to defrost it.

PERFORMANCE DATA (CONT)

Multiplication Factors

| HEATER VOLT RATING | | VOLTAGE DISTRIBUTION | | | | | MULTIPLICATION FACTOR | | | | |
|--------------------|-----|----------------------|--|--|--|--|-----------------------|--|--|--|--|
| 240 | 200 | 0.69 | | | | | | | | | |
| | 208 | 0.75 | | | | | | | | | |
| | 230 | 0.92 | | | | | | | | | |
| | 240 | 1.00 | | | | | | | | | |
| 480 | 460 | 0.92 | | | | | | | | | |

Dry Coil Air Delivery CFM* – Horizontal Discharge – Unit 24–60

| Unit | Motor Speed | Wire Color | External Static Pressure (IN. W.C.) | | | | | | | | | | | | |
|------|-----------------------|------------|-------------------------------------|------|------|------|------|------|------|------|------|-----|-----|-----|-----|
| | | | 0.1 | 0.2 | 0.3 | 0.4 | 0.5 | 0.6 | 0.7 | 0.8 | 0.9 | | | | |
| 24 | Low | Blue | 754 | 650 | 536 | 429 | --- | --- | --- | --- | --- | --- | --- | --- | --- |
| | Med-Low | Pink | 851 | 777 | 675 | 591 | 475 | --- | --- | --- | --- | --- | --- | --- | --- |
| | Medium ¹ | Red | 941 | 851 | 774 | 684 | 576 | 479 | --- | --- | --- | --- | --- | --- | --- |
| | Med-High | Orange | 1009 | 917 | 840 | 759 | 667 | 577 | 447 | --- | --- | --- | --- | --- | --- |
| | High | Black | 1241 | 1167 | 1111 | 1036 | 969 | 881 | 818 | 731 | 640 | --- | --- | --- | --- |
| | Low | Blue | 741 | 638 | 547 | 415 | --- | --- | --- | --- | --- | --- | --- | --- | --- |
| 30 | Med-Low | Pink | 973 | 887 | 823 | 733 | 665 | 538 | 451 | --- | --- | --- | --- | --- | --- |
| | Medium | Red | 1088 | 1023 | 954 | 881 | 800 | 723 | 658 | 563 | 461 | --- | --- | --- | --- |
| | Med-High ¹ | Orange | 1140 | 1064 | 996 | 915 | 840 | 758 | 687 | 564 | 480 | --- | --- | --- | --- |
| | High | Black | 1202 | 1140 | 1082 | 1015 | 961 | 881 | 811 | 732 | 631 | --- | --- | --- | --- |
| | Low | Blue | 1176 | 1121 | 1079 | 1019 | 974 | 920 | 877 | 826 | 754 | --- | --- | --- | --- |
| | Med-Low | Pink | 1295 | 1234 | 1182 | 1126 | 1075 | 1016 | 955 | 898 | 857 | --- | --- | --- | --- |
| 36 | Medium ¹ | Red | 1345 | 1282 | 1235 | 1194 | 1140 | 1095 | 1027 | 974 | 921 | --- | --- | --- | --- |
| | Med-High | Orange | 1505 | 1452 | 1413 | 1358 | 1323 | 1282 | 1234 | 1169 | 1130 | --- | --- | --- | --- |
| | High | Black | 1705 | 1643 | 1607 | 1568 | 1518 | 1483 | 1448 | 1404 | 1360 | --- | --- | --- | --- |
| | Low | Blue | 1295 | 1234 | 1182 | 1126 | 1075 | 1016 | 955 | 898 | 857 | --- | --- | --- | --- |
| | Med-Low | Pink | 1345 | 1282 | 1235 | 1194 | 1140 | 1095 | 1027 | 974 | 921 | --- | --- | --- | --- |
| | Medium | Red | 1505 | 1452 | 1413 | 1358 | 1323 | 1282 | 1234 | 1169 | 1130 | --- | --- | --- | --- |
| 42 | Med-High ¹ | Orange | 1545 | 1492 | 1449 | 1411 | 1362 | 1313 | 1278 | 1231 | 1188 | --- | --- | --- | --- |
| | High | Black | 1705 | 1643 | 1607 | 1568 | 1518 | 1483 | 1448 | 1404 | 1360 | --- | --- | --- | --- |
| | Low | Blue | 1430 | 1374 | 1327 | 1267 | 1223 | 1176 | 1127 | 1061 | 1016 | --- | --- | --- | --- |
| | Med-Low | Pink | 1445 | 1389 | 1341 | 1281 | 1236 | 1189 | 1139 | 1072 | 1027 | --- | --- | --- | --- |
| | Medium ¹ | Red | 1678 | 1635 | 1602 | 1558 | 1513 | 1474 | 1438 | 1404 | 1349 | --- | --- | --- | --- |
| | Med-High | Orange | 2131 | 2088 | 2065 | 2013 | 1982 | 1941 | 1888 | 1860 | 1785 | --- | --- | --- | --- |
| 48 | High | Black | 2461 | 2409 | 2339 | 2286 | 2192 | 2140 | 2062 | 1968 | 1874 | --- | --- | --- | --- |
| | Low | Blue | 1445 | 1389 | 1341 | 1281 | 1236 | 1189 | 1139 | 1072 | 1027 | --- | --- | --- | --- |
| | Med-Low | Pink | 1678 | 1635 | 1602 | 1558 | 1513 | 1474 | 1438 | 1404 | 1349 | --- | --- | --- | --- |
| | Medium ¹ | Red | 1962 | 1915 | 1880 | 1843 | 1794 | 1753 | 1711 | 1675 | 1628 | --- | --- | --- | --- |
| | Med-High | Orange | 2131 | 2088 | 2065 | 2013 | 1982 | 1941 | 1888 | 1860 | 1785 | --- | --- | --- | --- |
| | High | Black | 2461 | 2409 | 2339 | 2286 | 2192 | 2140 | 2062 | 1968 | 1874 | --- | --- | --- | --- |

* Air delivery values are without air filter and are for dry coil (See Wet Coil Pressure Drop Table).

¹ Factory-shipped cooling/heat pump heating speed

NOTE: Duct field-supplied air filter pressure drop and wet coil pressure drop to obtain external static pressure available for ducting.

Shaded areas indicate speed/static combinations that are not permitted for dehumidification speed.

Note: Deduct 10% for 208 volt operation.

Dry Coil Air Delivery – Downflow Discharge

| UNIT | MOTOR SPEED | WIRE COLOR | EXTERNAL STATIC PRESSURE (IN. W.C.) | | | | | | | | | | |
|---------------------|----------------------|------------|-------------------------------------|------|------|------|------|------|------|------|------|------|------|
| | | | 0.10 | 0.20 | 0.30 | 0.40 | 0.50 | 0.60 | 0.70 | 0.80 | 0.90 | 1.0 | |
| 42 | Low | CFM | 1365 | 1324 | 1283 | 1243 | 1203 | 1163 | 1123 | 1084 | 1039 | 984 | 939 |
| | | WATTS | 177 | 189 | 201 | 210 | 222 | 236 | 248 | 261 | 269 | 281 | 281 |
| | | BHP | 0.19 | 0.20 | 0.22 | 0.23 | 0.24 | 0.25 | 0.27 | 0.28 | 0.29 | 0.30 | 0.30 |
| | MedLow | CFM | 1425 | 1384 | 1339 | 1301 | 1254 | 1199 | 1151 | 1104 | 1065 | 1015 | 1015 |
| | | WATTS | 197 | 210 | 223 | 235 | 248 | 257 | 271 | 284 | 296 | 305 | 305 |
| | | BHP | 0.21 | 0.23 | 0.24 | 0.25 | 0.27 | 0.28 | 0.29 | 0.30 | 0.32 | 0.33 | 0.33 |
| | Medium | CFM | 1582 | 1549 | 1509 | 1469 | 1433 | 1392 | 1346 | 1300 | 1249 | 1213 | 1213 |
| | | WATTS | 267 | 280 | 294 | 308 | 322 | 336 | 344 | 359 | 374 | 387 | 387 |
| | | BHP | 0.29 | 0.30 | 0.32 | 0.33 | 0.35 | 0.36 | 0.37 | 0.38 | 0.40 | 0.42 | 0.42 |
| | MedHigh ¹ | CFM | 1623 | 1586 | 1553 | 1511 | 1470 | 1433 | 1393 | 1350 | 1309 | 1261 | 1261 |
| | | WATTS | 285 | 299 | 312 | 324 | 335 | 349 | 363 | 378 | 393 | 407 | 407 |
| | | BHP | 0.31 | 0.32 | 0.33 | 0.35 | 0.36 | 0.37 | 0.39 | 0.41 | 0.42 | 0.44 | 0.44 |
| High | CFM | 1775 | 1736 | 1696 | 1660 | 1622 | 1588 | 1557 | 1516 | 1472 | 1426 | 1426 | |
| | WATTS | 371 | 386 | 401 | 410 | 424 | 439 | 453 | 468 | 483 | 497 | 497 | |
| | BHP | 0.40 | 0.41 | 0.43 | 0.44 | 0.45 | 0.47 | 0.49 | 0.50 | 0.52 | 0.53 | 0.53 | |
| Low | CFM | 1491 | 1445 | 1403 | 1358 | 1306 | 1261 | 1199 | 1169 | 1122 | 1069 | 1069 | |
| | WATTS | 232 | 239 | 254 | 262 | 278 | 293 | 303 | 316 | 323 | 335 | 335 | |
| | BHP | 0.25 | 0.26 | 0.27 | 0.28 | 0.30 | 0.31 | 0.32 | 0.34 | 0.35 | 0.36 | 0.36 | |
| MedLow | CFM | 1479 | 1436 | 1387 | 1346 | 1298 | 1253 | 1206 | 1160 | 1114 | 1061 | 1061 | |
| | WATTS | 224 | 239 | 247 | 262 | 270 | 284 | 300 | 307 | 319 | 330 | 330 | |
| | BHP | 0.24 | 0.26 | 0.26 | 0.28 | 0.29 | 0.30 | 0.32 | 0.33 | 0.34 | 0.35 | 0.35 | |
| Medium ¹ | CFM | 1813 | 1785 | 1745 | 1709 | 1663 | 1632 | 1592 | 1548 | 1506 | 1450 | 1450 | |
| | WATTS | 411 | 427 | 435 | 451 | 462 | 478 | 489 | 504 | 518 | 529 | 529 | |
| | BHP | 0.44 | 0.46 | 0.47 | 0.48 | 0.50 | 0.51 | 0.52 | 0.54 | 0.56 | 0.57 | 0.57 | |
| MedHigh | CFM | 2178 | 2148 | 2105 | 2073 | 2036 | 2002 | 1967 | 1919 | 1845 | 1751 | 1751 | |
| | WATTS | 674 | 691 | 703 | 717 | 733 | 743 | 758 | 754 | 734 | 701 | 701 | |
| | BHP | 0.72 | 0.74 | 0.75 | 0.77 | 0.79 | 0.80 | 0.81 | 0.81 | 0.79 | 0.75 | 0.75 | |
| High | CFM | 2480 | 2432 | 2375 | 2322 | 2236 | 2161 | 2085 | 2006 | 1917 | 1808 | 1808 | |
| | WATTS | 1029 | 1012 | 995 | 975 | 941 | 908 | 869 | 836 | 796 | 751 | 751 | |
| | BHP | 1.10 | 1.09 | 1.07 | 1.05 | 1.01 | 0.97 | 0.93 | 0.90 | 0.85 | 0.81 | 0.81 | |
| Low | CFM | 1479 | 1436 | 1387 | 1346 | 1298 | 1253 | 1206 | 1160 | 1114 | 1061 | 1061 | |
| | WATTS | 224 | 239 | 247 | 262 | 270 | 284 | 300 | 307 | 319 | 330 | 330 | |
| | BHP | 0.24 | 0.26 | 0.26 | 0.28 | 0.29 | 0.30 | 0.32 | 0.33 | 0.34 | 0.35 | 0.35 | |
| MedLow | CFM | 1841 | 1796 | 1761 | 1724 | 1690 | 1651 | 1616 | 1578 | 1527 | 1478 | 1478 | |
| | WATTS | 425 | 434 | 453 | 460 | 476 | 485 | 501 | 508 | 525 | 542 | 542 | |
| | BHP | 0.46 | 0.47 | 0.49 | 0.49 | 0.51 | 0.52 | 0.54 | 0.54 | 0.56 | 0.58 | 0.58 | |
| Medium ¹ | CFM | 1944 | 1913 | 1872 | 1838 | 1801 | 1771 | 1731 | 1698 | 1655 | 1613 | 1613 | |
| | WATTS | 486 | 501 | 511 | 529 | 537 | 554 | 565 | 578 | 595 | 603 | 603 | |
| | BHP | 0.52 | 0.54 | 0.55 | 0.57 | 0.58 | 0.59 | 0.61 | 0.62 | 0.64 | 0.65 | 0.65 | |
| MedHigh | CFM | 2178 | 2148 | 2105 | 2073 | 2036 | 2002 | 1967 | 1919 | 1845 | 1751 | 1751 | |
| | WATTS | 674 | 691 | 703 | 717 | 733 | 743 | 758 | 754 | 734 | 701 | 701 | |
| | BHP | 0.72 | 0.74 | 0.75 | 0.77 | 0.79 | 0.80 | 0.81 | 0.81 | 0.79 | 0.75 | 0.75 | |
| High | CFM | 2480 | 2432 | 2375 | 2322 | 2236 | 2161 | 2085 | 2006 | 1917 | 1808 | 1808 | |
| | WATTS | 1029 | 1012 | 995 | 975 | 941 | 908 | 869 | 836 | 796 | 751 | 751 | |
| | BHP | 1.10 | 1.09 | 1.07 | 1.05 | 1.01 | 0.97 | 0.93 | 0.90 | 0.85 | 0.81 | 0.81 | |

*Air delivery values are without air filter and are for dry coil (See Wet Coil Pressure Drop table).

¹ Factory-shipped cooling speed.

NOTE: Ducted field-supplied air filter pressure drop and wet coil pressure drop to obtain external static pressure available for ducting. Shaded areas indicate speed/static combinations that are not permitted.

PERFORMANCE DATA (CONT)
Filter Pressure Drop Table (IN. W.C.)

| FILTER SIZE IN. (MM) | COOLING TONS | STANDARD CFM (SCFM) | | | | | | | | | | | | | | | | |
|--|--------------|---------------------|------|------|------|------|------|------|------|------|------|------|------|------|------|------|------|------|
| | | 600 | 700 | 800 | 900 | 1000 | 1100 | 1200 | 1300 | 1400 | 1500 | 1600 | 1700 | 1800 | 1900 | 2000 | 2100 | 2200 |
| 600-1400 CFM 12x20x1+12x20x1 (305x508x25+305x508x25) | 2.0, | | | | | | | | | | | | | | | | | |
| | 2.5, | 0.03 | 0.04 | 0.05 | 0.06 | 0.06 | 0.07 | 0.07 | 0.08 | 0.08 | - | - | - | - | - | - | - | - |
| | 3.0 | | | | | | | | | | | | | | | | | |
| 1200-1800CFM 16x24x1+14x24x1 (406x610x25+356x610x25) | 3.5, | - | - | - | - | 0.04 | 0.05 | 0.06 | 0.07 | 0.08 | 0.09 | 0.10 | 0.11 | 0.12 | 0.12 | - | - | - |
| | 4.0 | | | | | | | | | | | | | | | | | |
| | 5.0 | - | - | - | - | - | - | - | - | - | 0.04 | 0.06 | 0.08 | 0.10 | 0.11 | 0.13 | 0.14 | 0.15 |

Wet Coil Pressure Drop (IN. W.C.)

| UNIT SIZE | STANDARD CFM (SCFM) | | | | | | | | | | | | | | | | |
|-----------|---------------------|------|------|------|------|------|------|------|------|------|------|------|------|------|------|------|------|
| | 600 | 700 | 800 | 900 | 1000 | 1100 | 1200 | 1300 | 1400 | 1500 | 1600 | 1700 | 1800 | 1900 | 2000 | 2100 | 2200 |
| 24 | 0.03 | 0.04 | 0.04 | 0.05 | 0.06 | | | | | | | | | | | | |
| 30 | | | | 0.05 | 0.06 | 0.07 | 0.08 | 0.11 | | | | | | | | | |
| 36 | | | | 0.06 | 0.06 | 0.09 | 0.10 | 0.11 | 0.14 | | | | | | | | |
| 42 | | | | 0.06 | 0.05 | 0.05 | 0.06 | 0.07 | 0.08 | 0.08 | 0.09 | 0.09 | 0.11 | | | | |
| 48 | | | | | | | 0.04 | 0.06 | 0.09 | 0.10 | 0.10 | 0.11 | 0.12 | 0.13 | 0.14 | | |
| 60 | | | | | | | | 0.06 | 0.09 | 0.06 | 0.07 | 0.01 | 0.08 | 0.09 | 0.10 | 0.12 | 0.13 |

Economizer with 1-in. Filter Pressure Drop (IN. W.C.)

| FILTER SIZE IN. (MM) | COOLING TONS | STANDARD CFM (SCFM) | | | | | | | | | | | | | | | | |
|--|--------------|---------------------|-----|------|------|------|------|------|------|------|------|------|------|------|------|------|------|------|
| | | 600 | 700 | 800 | 900 | 1000 | 1100 | 1200 | 1300 | 1400 | 1500 | 1600 | 1700 | 1800 | 1900 | 2000 | 2100 | 2200 |
| 600-1400 CFM 12x20x1+12x20x1 (305x508x25+305x508x25) | 2.0, | | | | | | | | | | | | | | | | | |
| | 2.5, | - | - | 0.08 | 0.09 | 0.10 | 0.10 | 0.11 | 0.13 | 0.14 | - | - | - | - | - | - | - | - |
| | 3.0 | | | | | | | | | | | | | | | | | |
| 1200-1800CFM 16x24x1+14x24x1 (406x610x25+356x610x25) | 3.5, | - | - | - | - | - | - | 0.09 | 0.10 | 0.12 | 0.13 | 0.15 | 0.17 | 0.17 | 0.19 | 0.21 | - | - |
| | 4.0 | | | | | | | | | | | | | | | | | |
| | 5.0 | - | - | - | - | - | - | - | - | - | 0.15 | 0.17 | 0.18 | 0.20 | 0.21 | 0.22 | 0.23 | 0.23 |

**Electric Heat Pressure Drop Table (IN. W.C.)
Small Cabinet: 24-36**

| STATIC | STANDARD CFM (SCFM) | | | | | | | | | | | | | | | | | |
|--------|---------------------|------|------|------|------|------|------|------|------|------|------|------|------|------|------|------|------|------|
| | 500 | 600 | 700 | 800 | 900 | 1000 | 1100 | 1200 | 1300 | 1400 | 1500 | 1600 | 1700 | 1800 | 1900 | 2000 | 2100 | 2200 |
| 5kw | 0.00 | 0.00 | 0.00 | 0.00 | 0.00 | 0.00 | 0.00 | 0.00 | 0.00 | 0.00 | 0.00 | 0.00 | 0.02 | 0.02 | 0.04 | 0.06 | 0.07 | 0.07 |
| 7.5 kw | 0.00 | 0.00 | 0.00 | 0.00 | 0.00 | 0.00 | 0.00 | 0.00 | 0.00 | 0.00 | 0.00 | 0.03 | 0.05 | 0.07 | 0.08 | 0.08 | 0.09 | 0.09 |
| 10 kw | 0.00 | 0.00 | 0.00 | 0.00 | 0.00 | 0.02 | 0.02 | 0.02 | 0.04 | 0.04 | 0.06 | 0.07 | 0.07 | 0.09 | 0.10 | 0.10 | 0.11 | 0.11 |
| 15 kw | 0.00 | 0.00 | 0.00 | 0.02 | 0.04 | 0.06 | 0.06 | 0.06 | 0.08 | 0.08 | 0.10 | 0.10 | 0.12 | 0.14 | 0.16 | 0.16 | 0.18 | 0.18 |
| 20 kw | 0.00 | 0.00 | 0.02 | 0.04 | 0.06 | 0.08 | 0.08 | 0.08 | 0.09 | 0.09 | 0.11 | 0.11 | 0.13 | 0.15 | 0.17 | 0.17 | 0.19 | 0.19 |

**Electric Heat Pressure Drop Table (IN. W.C.)
Large Cabinet 42-60**

| STATIC | STANDARD CFM (SCFM) | | | | | | | | | | | | | | | |
|--------|---------------------|------|------|------|------|------|------|------|------|------|------|------|------|------|------|--|
| | 1100 | 1200 | 1300 | 1400 | 1500 | 1600 | 1700 | 1800 | 1900 | 2000 | 2100 | 2200 | 2300 | 2400 | 2500 | |
| 5kw | 0.00 | 0.00 | 0.00 | 0.01 | 0.02 | 0.03 | 0.04 | 0.05 | 0.06 | 0.07 | 0.08 | 0.09 | 0.10 | 0.11 | 0.12 | |
| 7.5 kw | 0.00 | 0.00 | 0.01 | 0.02 | 0.03 | 0.04 | 0.05 | 0.06 | 0.07 | 0.08 | 0.09 | 0.10 | 0.11 | 0.12 | 0.13 | |
| 10 kw | 0.00 | 0.00 | 0.01 | 0.02 | 0.03 | 0.04 | 0.05 | 0.06 | 0.07 | 0.08 | 0.09 | 0.10 | 0.11 | 0.12 | 0.13 | |
| 15 kw | 0.00 | 0.02 | 0.03 | 0.04 | 0.05 | 0.06 | 0.07 | 0.08 | 0.09 | 0.10 | 0.11 | 0.12 | 0.13 | 0.14 | 0.15 | |
| 20 kw | 0.02 | 0.03 | 0.04 | 0.05 | 0.06 | 0.07 | 0.08 | 0.09 | 0.10 | 0.11 | 0.12 | 0.13 | 0.14 | 0.15 | 0.16 | |

TYPICAL PIPING AND WIRING

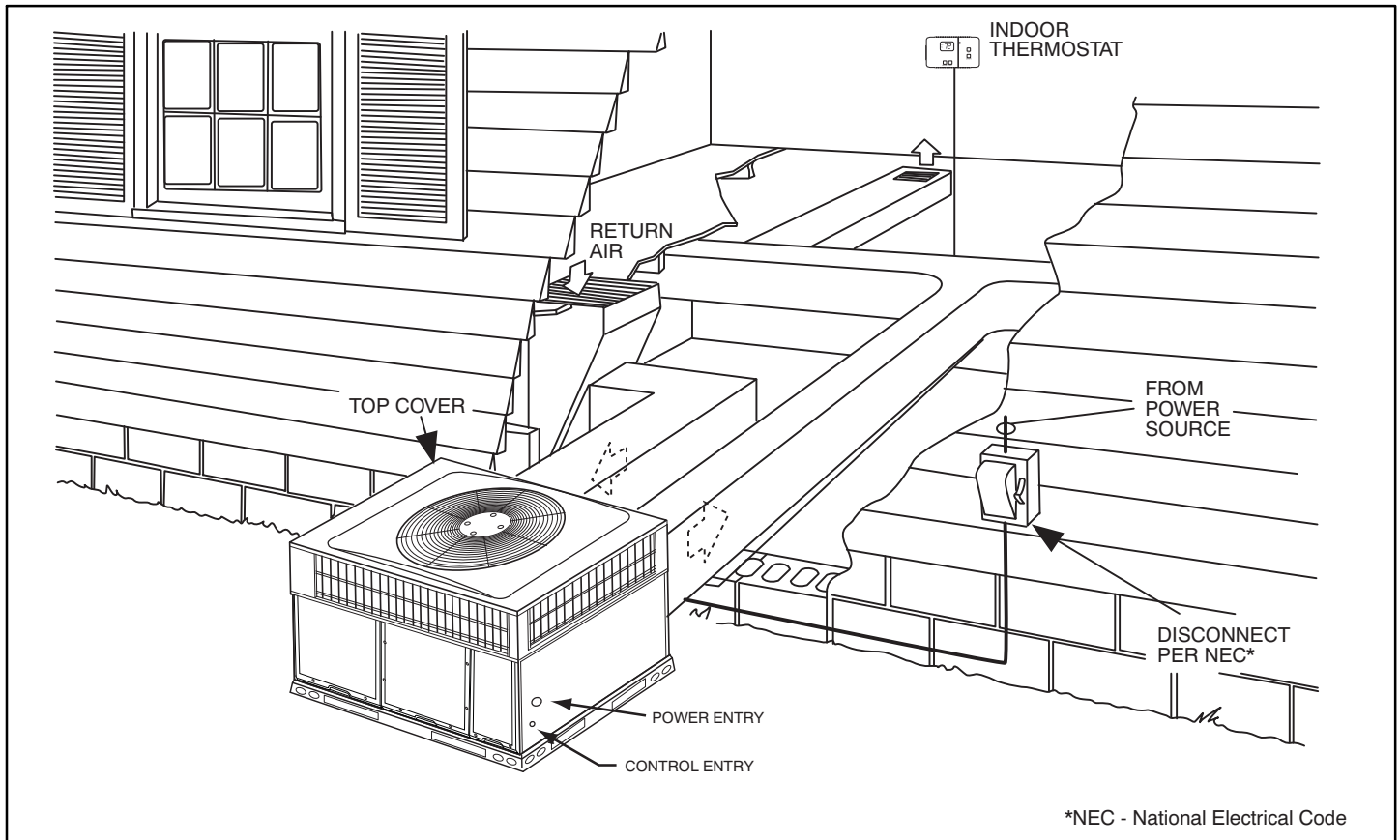

APPLICATION DATA

Condensate trap — A 2-in. (51 mm) condensate trap must be field supplied.

Ductwork — Secure downflow discharge ductwork to roof curb. For horizontal discharge applications, attach ductwork to unit with flanges.

To convert a unit to downflow discharge — Units are equipped with factory-installed inserts in the downflow openings. Removal of the inserts is similar to removing an electrical knock-out. Units installed in horizontal discharge orientation do not require duct covers.

Maximum cooling airflow — To minimize the possibility of condensate blow-off from the evaporator, airflow through the units should not exceed 450 CFM per ton.

Minimum cooling airflow — Minimum cooling airflow is 350 CFM per ton in cooling mode. Airflow can be lower in certain modes when humidity removal is an issue however, low airflow could result in indoor coil freezing and/or refrigerant floodback.

Minimum ambient cooling operation temperature — All standard units have a minimum ambient cooling operating temperature of 40°F (4.4°C). With accessory low ambient temperature kit, units can operate at temperatures down to 0°F (17.8°C).

Maximum operating outdoor air temperature for cooling is 125°F (51.7°C).

BALANCE POINT WORKSHEET

BALANCE POINT WORKSHEET

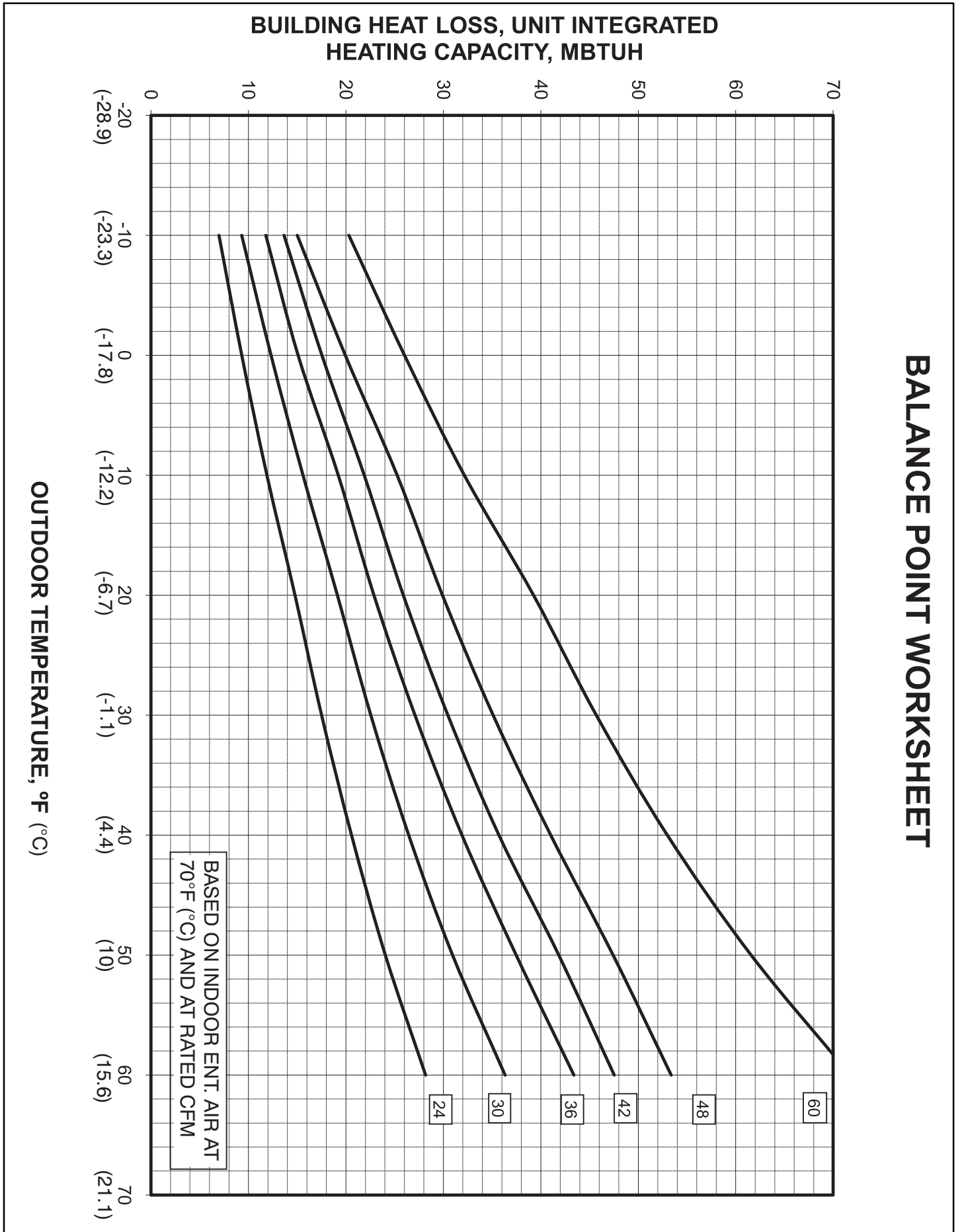

ELECTRICAL DATA

| MODEL | NOMINAL V-PH-HZ | VOLTAGE RANGE | | COMPRESSOR | | OFM | IFM | ELECTRIC HEAT | | POWER SUPPLY | MOCP |
|-------|-----------------|---------------|-----|------------|------|-----|-----|---------------|-----------|--------------|---------|
| | | MIN | MAX | RLA | LRA | FLA | FLA | NOMINAL kW | FLA | MCA | |
| 24 | 208/230-1-60 | 187 | 253 | 13.5 | 58.3 | 0.7 | 4.1 | -/- | -/- | 21.7 | 30 |
| | | | | | | | | 3.8/5 | 18.1/20.8 | 44.3/47.7 | 45/50 |
| | | | | | | | | 5.4/7.2 | 25.9/30 | 54.1/59.2 | 60/60 |
| | | | | | | | | 7.5/10 | 36.1/41.7 | 66.8/73.8 | 70/80 |
| 30 | 208/230-1-60 | 187 | 253 | 14.1 | 73 | 1.2 | 4.1 | -/- | -/- | 22.9 | 35 |
| | | | | | | | | 3.8/5 | 18.1/20.8 | 45.6/48.9 | 50/50 |
| | | | | | | | | 5.4/7.2 | 25.9/30 | 55.3/60.4 | 60/70 |
| | | | | | | | | 7.5/10 | 36.1/41.7 | 68.1/75.1 | 70/80 |
| | 208/230-3-60 | 187 | 253 | 9 | 58 | 1.2 | 4.1 | -/- | -/- | 16.6 | 25 |
| | | | | | | | | 3.8/5 | 10.4/12 | 29.6/31.6 | 30/35 |
| | | | | | | | | 7.5/10 | 20.8/24.1 | 42.6/46.7 | 45/50 |
| | | | | | | | | 11.3/15 | 31.2/36.1 | 55.6/61.7 | 60/70 |
| 36 | 208/230-1-60 | 187 | 253 | 17.1 | 79 | 1.2 | 6.0 | -/- | -/- | 28.6 | 40 |
| | | | | | | | | 3.8/5 | 18.1/20.8 | 51.2/54.6 | 60/60 |
| | | | | | | | | 5.4/7.2 | 25.9/30 | 61/66.1 | 70/70 |
| | | | | | | | | 7.5/10 | 36.1/41.7 | 73.7/80.7 | 80/90 |
| | 208/230-3-60 | 187 | 253 | 11.5 | 73 | 1.2 | 6.0 | -/- | -/- | 21.6 | 30 |
| | | | | | | | | 3.8/5 | 10.4/12 | 34.6/36.6 | 35/40 |
| | | | | | | | | 7.5/10 | 20.8/24.1 | 47.6/51.7 | 50/60 |
| | | | | | | | | 11.3/15 | 31.2/36.1 | 60.6/66.7 | 70/70 |
| | 460-3-60 | 414 | 506 | 5.8 | 38 | 0.5 | 3.0 | -/- | -/- | 10.8 | 15 |
| | | | | | | | | 3.8/5 | 6 | 18.3/18.3 | 20 |
| | | | | | | | | 7.5/10 | 12 | 25.8/25.8 | 30 |
| | | | | | | | | 11.3/15 | 18 | 33.3/33.3 | 35 |
| 42 | 208/230-1-60 | 187 | 253 | 20.6 | 112 | 1.2 | 6.0 | -/- | -/- | 33 | 50 |
| | | | | | | | | 3.8/5 | 18.1/20.8 | 55.6/59 | 60/60 |
| | | | | | | | | 5.4/7.2 | 25.9/30 | 65.3/70.5 | 70/80 |
| | | | | | | | | 7.5/10 | 36.1/41.7 | 78.1/85.1 | 80/90 |
| | | | | | | | | 11.3/15 | 54.2/62.5 | 100.7/111.1 | 110/125 |
| | 208/230-3-60 | 187 | 253 | 13.5 | 88 | 1.2 | 6.0 | -/- | -/- | 24.1 | 35 |
| | | | | | | | | 3.8/5 | 10.4/12 | 37.1/39.1 | 40/40 |
| | | | | | | | | 7.5/10 | 20.8/24.1 | 50.1/54.2 | 60/60 |
| | | | | | | | | 11.3/15 | 31.2/36.1 | 63.1/69.2 | 70/70 |
| | | | | | | | | 15/20 | 41.4/47.9 | 75.8/84 | 80/90 |
| | 460-3-60 | 414 | 506 | 6.1 | 44 | 0.5 | 3.0 | -/- | -/- | 11.1 | 15 |
| | | | | | | | | 3.8/5 | 6 | 18.6/18.6 | 20 |
| | | | | | | | | 7.5/10 | 12 | 26.1/26.1 | 30 |
| | | | | | | | | 11.3/15 | 18 | 33.6/33.6 | 35 |
| | | | | | | | | 15/20 | 24.1 | 41.3/41.3 | 45 |
| | | | | | | | | -/- | -/- | 38.1 | 50 |
| 48 | 208/230-1-60 | 187 | 253 | 23.4 | 109 | 1.2 | 7.6 | -/- | -/- | 38.1 | 50 |
| | | | | | | | | 3.8/5 | 18.1/20.8 | 60.7/64.1 | 70/70 |
| | | | | | | | | 5.4/7.2 | 25.9/30 | 70.4/75.6 | 80/80 |
| | | | | | | | | 7.5/10 | 36.1/41.7 | 83.2/90.2 | 90/100 |
| | | | | | | | | 11.3/15 | 54.2/62.5 | 105.8/116.2 | 110/125 |
| | 208/230-3-60 | 187 | 253 | 16 | 83 | 1.2 | 7.6 | -/- | -/- | 28.8 | 40 |
| | | | | | | | | 3.8/5 | 10.4/12 | 41.8/43.8 | 45/45 |
| | | | | | | | | 7.5/10 | 20.8/24.1 | 54.8/58.9 | 60/60 |
| | | | | | | | | 11.3/15 | 31.2/36.1 | 67.8/73.9 | 70/80 |
| | | | | | | | | 15/19.91 | 41.4/47.9 | 80.6/88.7 | 90/90 |
| | 460-3-60 | 414 | 506 | 7.2 | 41 | 0.5 | 3.8 | -/- | -/- | 13.3 | 20 |
| | | | | | | | | 3.8/5 | 6 | 20.8/20.8 | 25 |
| | | | | | | | | 7.5/10 | 12 | 28.3/28.3 | 30 |
| | | | | | | | | 11.3/15 | 18 | 35.8/35.8 | 40 |
| | | | | | | | | 15/20 | 24.1 | 43.4/43.4 | 45 |
| | | | | | | | | -/- | -/- | 45.8 | 60 |
| 60 | 208/230-1-60 | 187 | 253 | 29.6 | 134 | 1.2 | 7.6 | -/- | -/- | 45.8 | 60 |
| | | | | | | | | 3.8/5 | 18.1/20.8 | 68.4/71.8 | 70/80 |
| | | | | | | | | 5.4/7.2 | 25.9/30 | 78.2/83.3 | 80/90 |
| | | | | | | | | 7.5/10 | 36.1/41.7 | 90.9/97.9 | 100/100 |
| | | | | | | | | 11.3/15 | 54.2/62.5 | 113.6/123.9 | 125/125 |
| | 208/230-3-60 | 187 | 253 | 19.9 | 110 | 1.2 | 7.6 | -/- | -/- | 33.7 | 50 |
| | | | | | | | | 3.8/5 | 10.4/12 | 46.7/48.7 | 50/50 |
| | | | | | | | | 7.5/10 | 20.8/24.1 | 59.7/63.8 | 60/70 |
| | | | | | | | | 11.3/15 | 31.2/36.1 | 72.7/78.8 | 80/80 |
| | | | | | | | | 15/19.91 | 41.4/47.9 | 85.4/93.6 | 90/100 |
| | 460-3-60 | 414 | 506 | 8.6 | 52 | 0.6 | 3.8 | -/- | -/- | 15.2 | 20 |
| | | | | | | | | 3.8/5 | 6 | 22.7/22.7 | 25 |
| | | | | | | | | 7.5/10 | 12 | 30.2/30.2 | 35 |
| | | | | | | | | 11.3/15 | 18 | 37.7/37.7 | 40 |
| | | | | | | | | 15/20 | 24.1 | 45.3/45.3 | 50 |
| | | | | | | | | -/- | -/- | 45.3/45.3 | 50 |

See Legend and Notes.

LEGEND

- FLA - Full Load Amps
- IFM - Indoor Fan Motor
- LRA - Locked Rotor Amps
- MCA - Minimum Circuit Amps
- MOCP - Maximum Over Current Protection
- OFM - Outdoor Fan Motor
- RLA - Rated Load Amps

NOTES:

1. In compliance with NEC (National Electrical Code) requirements for multimotor and combination load equipment (refer to NEC Articles 430 and 440), the overcurrent protective device for the unit shall be Power Supply fuse or circuit breaker.
2. Minimum wire size is based on 60 C copper wire. If other than 60 C wire is used, or if length exceeds wire length in table, determine size from NEC.
3. Unbalanced 3-Phase Supply Voltage
Never operate a motor where a phase imbalance in supply voltage is greater than 2%. Use the following formula to determine the percentage of voltage imbalance

% Voltage imbalance

$$= 100 \times \frac{\text{max voltage deviation from average voltage}}{\text{average voltage}}$$

EXAMPLE: Supply voltage is 230-3-60.

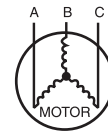

AB = 228 v
BC = 231 v
AC = 227 v

$$\begin{aligned} \text{Average Voltage} &= \frac{228 + 231 + 227}{3} \\ &= \frac{686}{3} \\ &= 229 \end{aligned}$$

Determine maximum deviation from average voltage.

(AB) 229 - 228 = 1 v
(BC) 231 - 229 = 2 v
(AC) 229 - 227 = 2 v

Maximum deviation is 2 v.

Determine percent of voltage imbalance

$$\begin{aligned} \% \text{ Voltage Imbalance} &= 100 \times \frac{2}{229} \\ &= 0.8\% \end{aligned}$$

This amount of phase imbalance is satisfactory as it is below the maximum allowable 2%.

IMPORTANT: If the supply voltage phase imbalance is more than 2%, contact your local electric utility company immediately.

TYPICAL CONNECTION WIRING SCHEMATIC - 208/230-1-60

CONNECTION WIRING DIAGRAM

DANGER: ELECTRICAL SHOCK HAZARD DISCONNECT POWER BEFORE SERVICING

**SCHEMATIC
208/230-1-60**

NOTES:

- IF ANY OF THE ORIGINAL WIRES FURNISHED ARE REPLACED, THEY MUST BE REPLACED WITH THE SAME WIRE OR ITS EQUIVALENT.
- SEE PRICE PAGES FOR THERMOSTATS.
- USE 75 DEG. COPPER CONDUCTORS FOR FIELD INSTALLATION.
- SEE INSTALLATION INSTRUCTIONS FOR PROPER HEATING AND COOLING CONNECTIONS FOR YOUR UNIT. INDOOR FAN MOTOR PLUGS - "DO NOT DISCONNECT UNDER LOAD"
- CCH NOT USED ON ALL UNITS.
- THIS FUSE IS MANUFACTURED BY LITTELFUSE, P/N 257003.
- UNIT FACTORY-SHIPED IN STD MODE.

LEGEND

- | | | | |
|-------|--|--------|----------------------------|
| △ | FIELD SPLICE | COMP | COMPRESSOR MOTOR |
| ○ | TERMINAL (MARKED) | DB | DEFROST BOARD |
| ○ | TERMINAL (UNMARKED) | DEHUM | DEHUMIDIFICATION MODE |
| ● | SPLICE (IF USED) | DFT | DEFROST TEMPERATURE SWITCH |
| ○ | SPLICE (MARKED) | DR | DEFROST RELAY |
| — | FACTORY WIRING | EQUIP | EQUIPMENT |
| --- | FIELD CONTROL WIRING | GND | GROUND |
| --- | FIELD POWER WIRING | HPS | HIGH PRESSURE SWITCH |
| --- | ACCESSORY OR OPTIONAL WIRING | HR | HEATER RELAY |
| --- | TO INDICATE COMMON POTENTIAL ONLY; NOT TO REPRESENT WIRING | IFB | INDOOR FAN BOARD |
| C | CONTACTOR | IFM | INDOOR FAN MOTOR |
| CAP 1 | CAPACITOR, COMP | LPS | LOW PRESSURE SWITCH |
| CCH | CRANK CASE HEATER | OFM | OUTDOOR FAN MOTOR |
| | | RVS | REVERSING VALVE |
| | | STD | STANDARD MODE |
| | | TRAN | TRANSFORMER |
| | | T-STAT | THERMOSTAT |

COLOR CODE

| | |
|-----|--------|
| BLK | BLACK |
| BLU | BLUE |
| BRN | BROWN |
| GRY | GRAY |
| GRN | GREEN |
| ORN | ORANGE |
| PNK | PINK |
| RED | RED |
| VIO | VIOLET |
| WHT | WHITE |
| YEL | YELLOW |

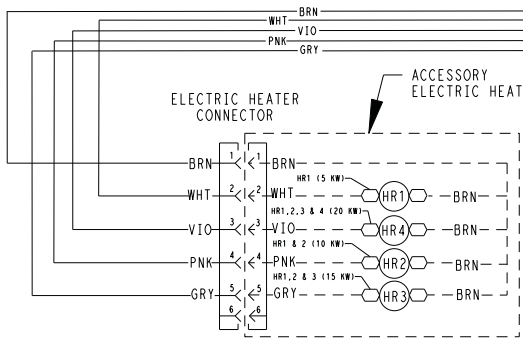
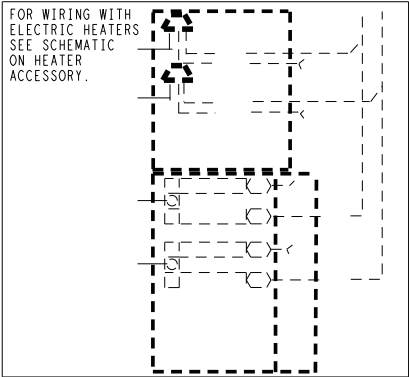
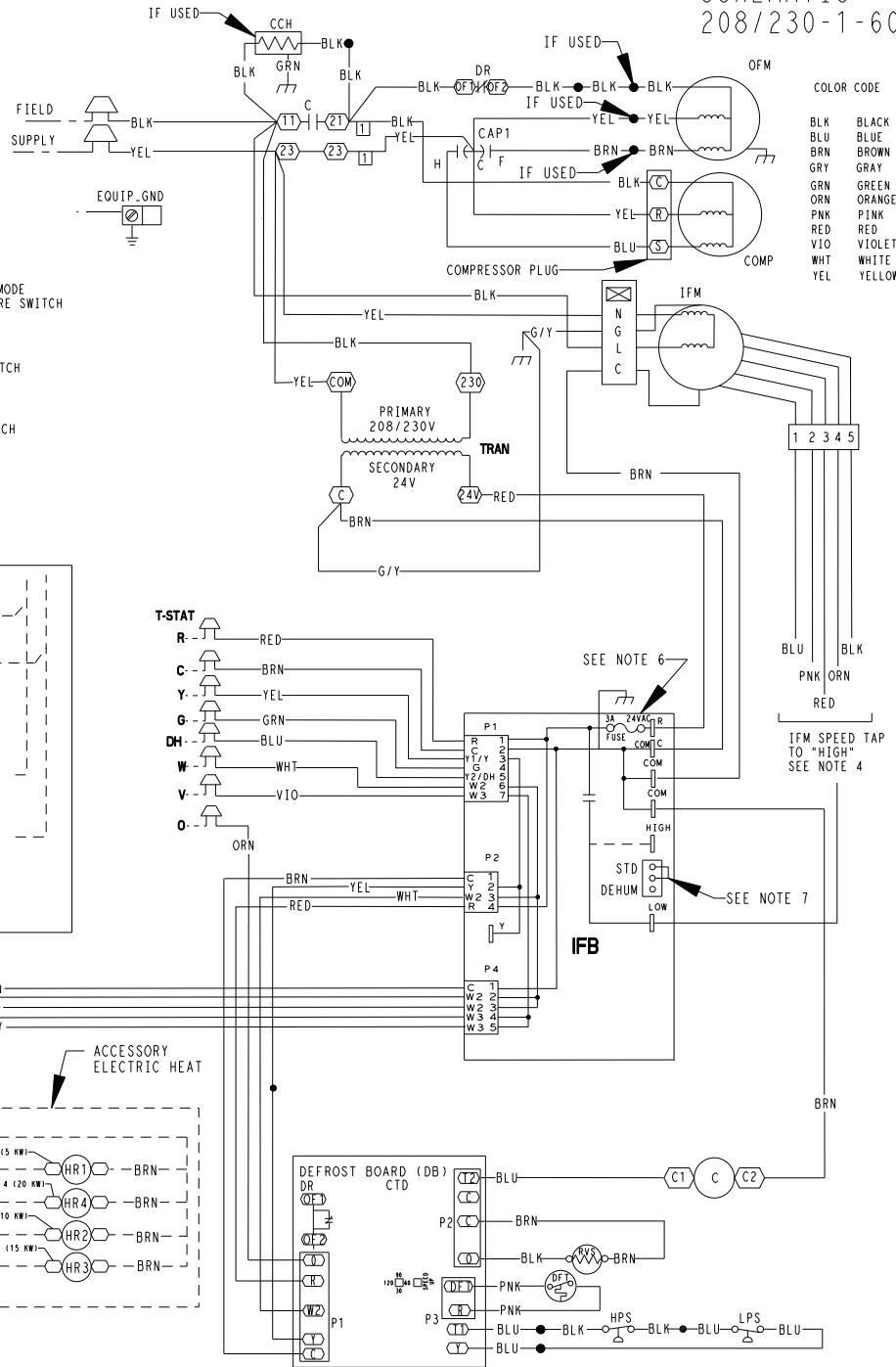

DIP SWITCH SETTINGS

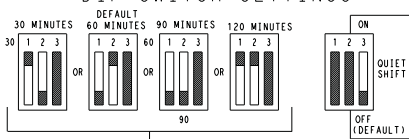

SPEED UP JUMPED TEST PINS (USE METAL OBJECT) FIELD SPEED-UP CYCLE

- MOMENTARILY SHORT PINS AND RELEASE TO BYPASS COMPRESSOR OFF DELAY.
- SHORT FOR 5+ SEC. AND RELEASE FOR FORCED DEFROST.
- PERMANENT SHORT WILL BE IGNORED.

DEFROST WILL TERMINATE IN 30 SEC. IF DFT OPEN. DEFROST WILL TERMINATE NORMALLY IF DFT IS CLOSED.
THE COMPRESSOR WILL SHUT OFF FOR 30 SEC. ON DEFROST INITIATION AND TERMINATION IN THE "QUIET SHIFT" ON POSITION

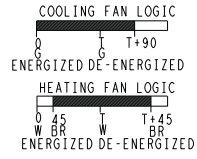

FIELD SELECTABLE OPTIONS FOR TIME PERIOD BETWEEN DEFROST CYCLES (MINUTES)

TYPICAL CONNECTION WIRING SCHEMATIC - 208/230-3-60

CONNECTION WIRING DIAGRAM

DANGER: ELECTRICAL SHOCK HAZARD DISCONNECT POWER BEFORE SERVICING

SCHEMATIC
208/230-3-60

NOTES:

1. IF ANY OF THE ORIGINAL WIRES FURNISHED ARE REPLACED, THEY MUST BE REPLACED WITH THE SAME WIRE OR ITS EQUIVALENT.
2. SEE PRICE PAGES FOR THERMOSTATS.
3. USE 75 DEG. COPPER CONDUCTORS FOR FIELD INSTALLATION.
4. SEE INSTALLATION INSTRUCTIONS FOR PROPER HEATING AND COOLING CONNECTIONS FOR YOUR UNIT. INDOOR FAN MOTOR PLUGS - "DO NOT DISCONNECT UNDER LOAD"
5. THIS FUSE IS MANUFACTURED BY LITTELFUSE, P/N 257003.
6. REMOVE YELLOW SPlice WIRE WHEN ECONOMIZER AND ECONOMIZER RELAYS ARE USED AND CONNECT TO RELAY R1 AS SHOWN.
7. WHEN ECONOMIZER AND ECONOMIZER RELAYS ARE USED, CONNECT THE YELLOW AND BLACK WIRES TO RELAY R AS SHOWN. RELAY R1 IS REQUIRED WITH ECONOMIZER AND HEAT PUMP/DUAL FUEL UNITS.
8. WHEN ECONOMIZER AND ECONOMIZER RELAYS ARE USED, INSTALL WIRES AS SHOWN ONTO THE COILS OF RELAY R AND RELAY R1.
9. DEHUM FEATURE CANNOT BE USED WHEN ECONOMIZER IS INSTALLED. UNIT FACTORY-SHIPED IN STD MODE.

- LEGEND**
- | | | |
|-------|------------------------------|-------------------|
| △ | FIELD SPlice | GROUND |
| ○ | TERMINAL (MARKED) | HPS |
| ○ | TERMINAL (UNMARKED) | HR |
| ○ | SPlice (IF USED) | IFB |
| ○ | SPlice (MARKED) | IFM |
| --- | FACTORY WIRING | LPS |
| --- | FIELD CONTROL WIRING | OPM |
| --- | FIELD POWER WIRING | OUTDOOR FAN MOTOR |
| --- | ACCESSORY OR OPTIONAL WIRING | RVS |
| C | CONTACTOR | TRAN |
| CAP 1 | CAPACITOR, COMP | T-STAT |
| CCH | CRANK CASE HEATER | R |
| COMP | COMPRESSOR MOTOR | R1 |
| DB | DEFROST BOARD | STD |
| DH | DEHUMIDIFICATION MODE | |
| DEHUM | DEHUMIDIFICATION SWITCH | |
| DFT | DEFROST TEMPERATURE SWITCH | |
| DR | DEFROST RELAY | |
| ECON | ECONOMIZER | |
| EQUIP | EQUIPMENT | |

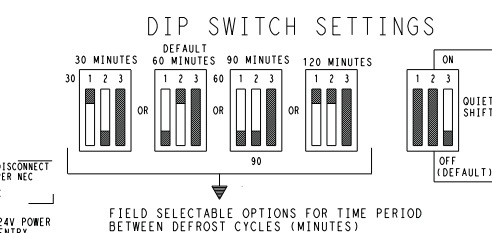
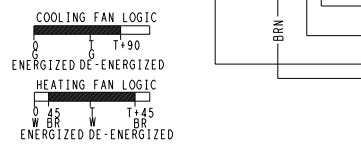
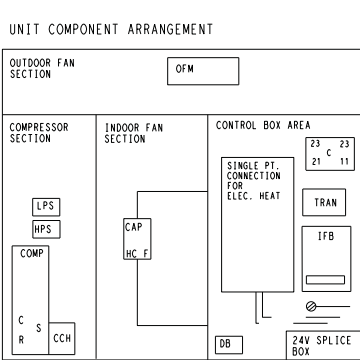
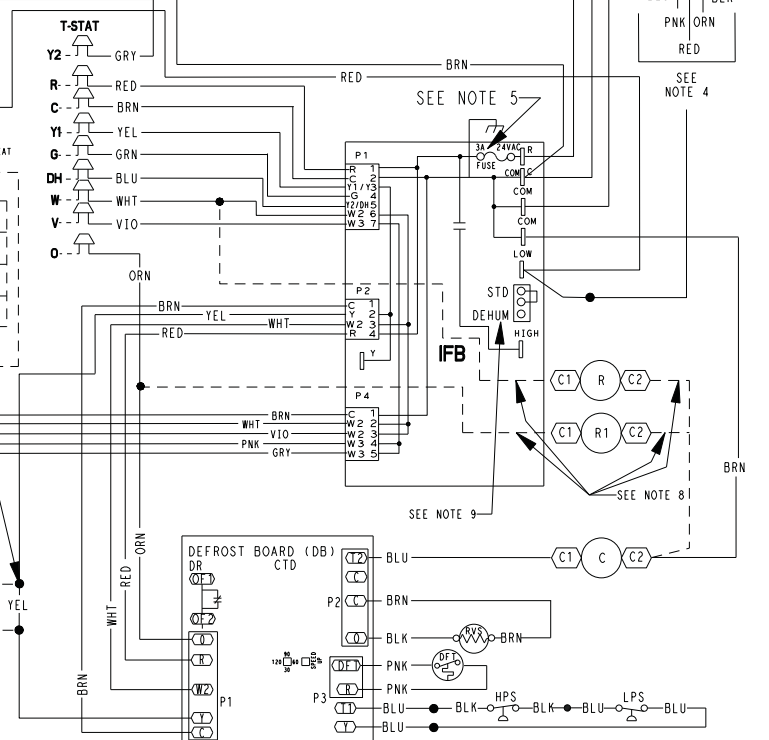
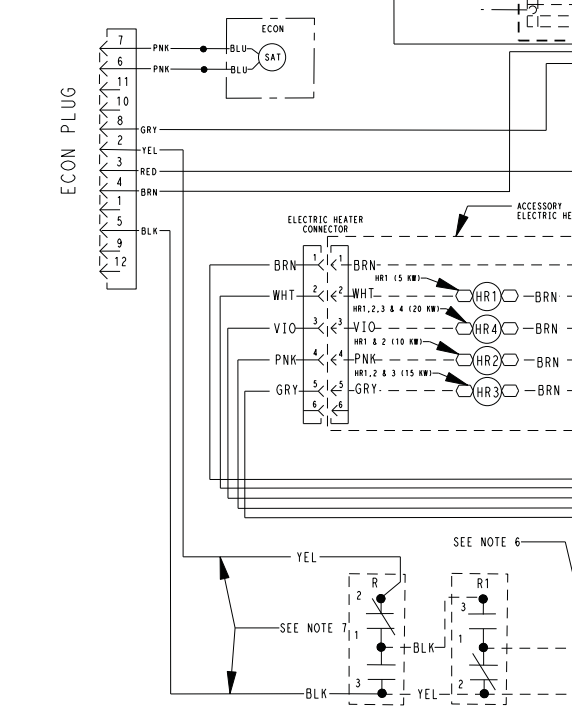
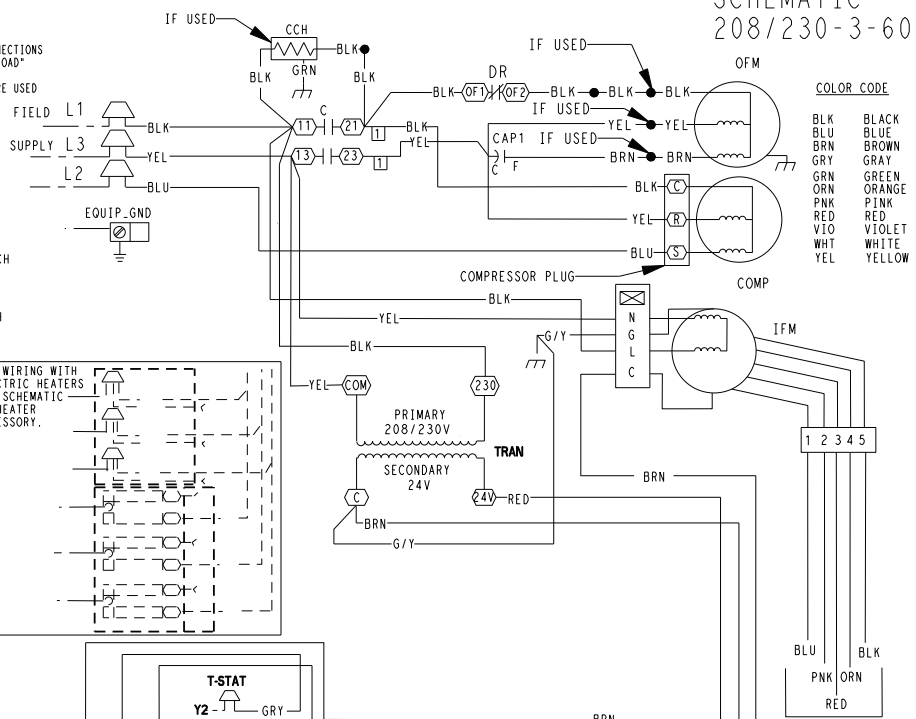

- SPEED UP** **JUMPED TEST PINS (USE METAL OBJECT) FIELD SPEED-UP CYCLE**
- 1) MOMENTARILY SHORT PINS AND RELEASE TO BYPASS COMPRESSOR OFF DELAY.
 - 2) SHORT FOR 5+ SEC. AND RELEASE FOR FORCED DEFROST.
 - 3) PERMANENT SHORT WILL BE IGNORED.
- DEFROST WILL TERMINATE IN 30 SEC. IF DFT OPEN.
DEFROST WILL TERMINATE NORMALLY IF DFT IS CLOSED.
- THE COMPRESSOR WILL SHUT OFF FOR 30 SEC. ON DEFROST INITIATION AND TERMINATION IN THE "QUIET SHIFT" ON POSITION

TYPICAL LADDER WIRING SCHEMATIC – 208/230–3–60

LADDER WIRING DIAGRAM

DANGER: ELECTRICAL SHOCK HAZARD DISCONNECT POWER BEFORE SERVICING

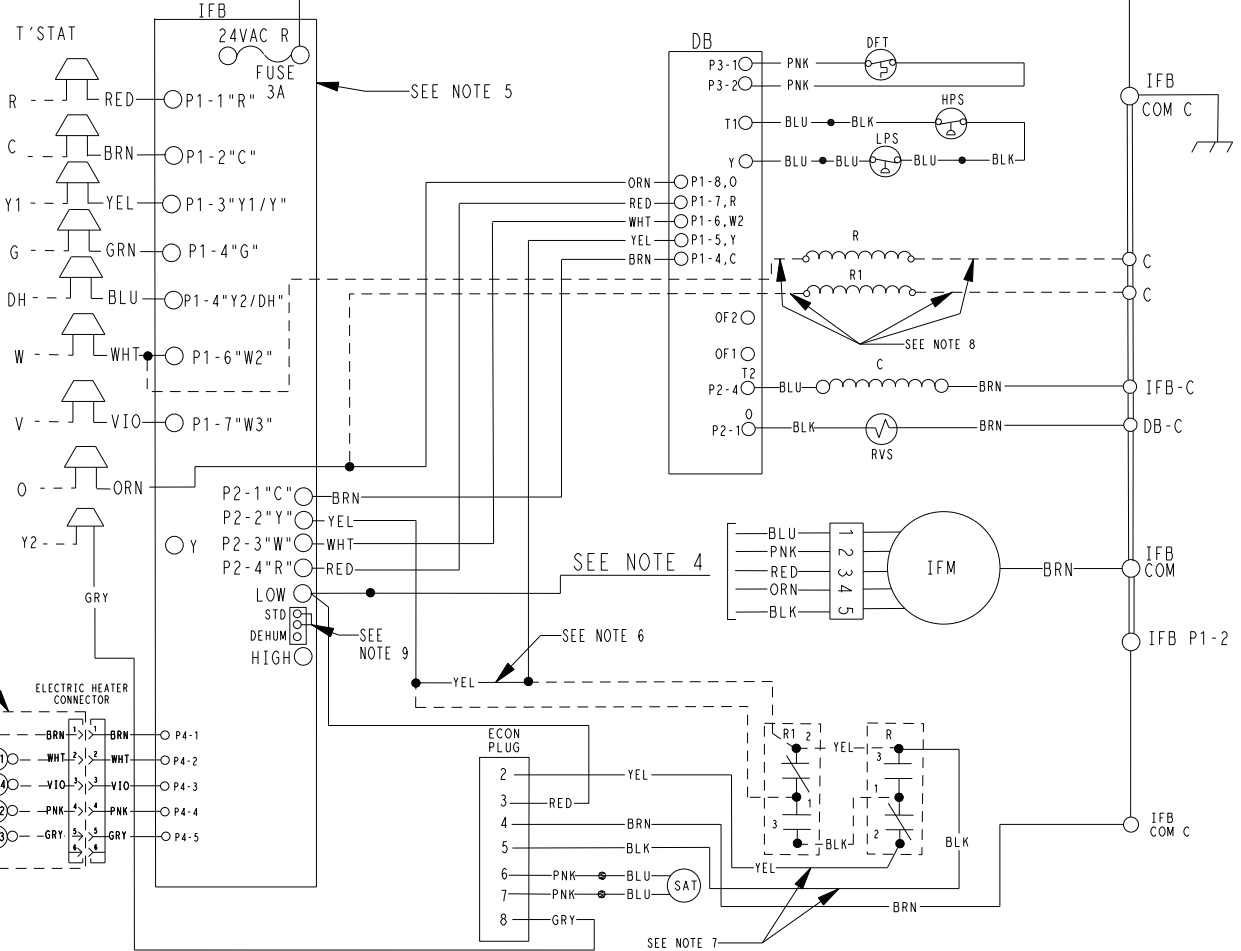
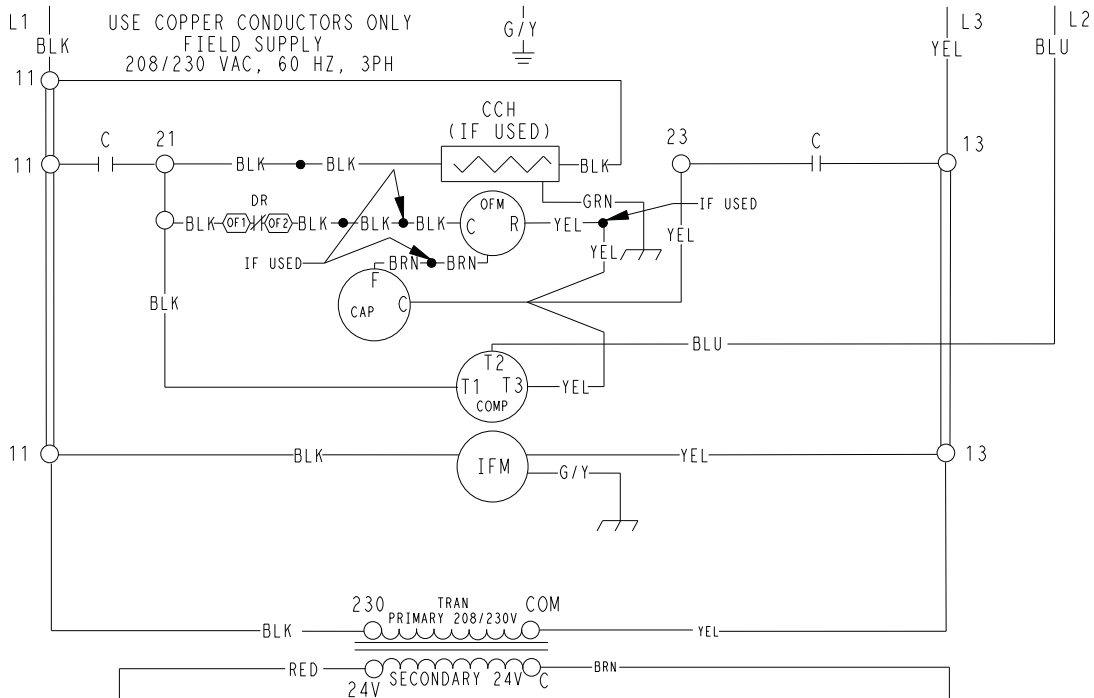

50EZ500356 E

TYPICAL CONNECTION WIRING SCHEMATIC - 460-3-60

CONNECTION WIRING DIAGRAM

DANGER: ELECTRICAL SHOCK HAZARD DISCONNECT POWER BEFORE SERVICING

SCHEMATIC
460-3-60

NOTES:

- IF ANY OF THE ORIGINAL WIRES FURNISHED ARE REPLACED, THEY MUST BE REPLACED WITH THE SAME WIRE OR ITS EQUIVALENT.
- SEE PRICE PAGES FOR THERMOSTATS.
- USE 75 DEG. COPPER CONDUCTORS FOR FIELD INSTALLATION.
- SEE INSTALLATION INSTRUCTIONS FOR PROPER HEATING AND COOLING CONNECTIONS FOR YOUR UNIT. INDOOR FAN MOTOR PLUGS - "DO NOT DISCONNECT UNDER LOAD".
- THESE FUSES ARE MANUFACTURED BY COOPER BUSSMANN, P/N FNO-R-5.
- THIS FUSE IS MANUFACTURED BY LITTELFUSE, P/N 257003.
- REMOVE YELLOW SPLICE WHEN ECONOMIZER AND ECONOMIZER RELAYS ARE USED AND CONNECT TO RELAY R1 AS SHOWN.
- WHEN ECONOMIZER AND ECONOMIZER RELAYS ARE USED, CONNECT THE YELLOW AND BLACK WIRES TO RELAY "R" AS SHOWN. RELAY KIT REQUIRED WITH ECONOMIZER AND HEAT PUMP/DUAL FUEL UNITS.
- WHEN ECONOMIZER AND ECONOMIZER RELAYS ARE USED, INSTALL WIRES AS SHOWN ONTO THE COILS OF RELAY R AND RELAY R1.
- DEHUM FEATURE CANNOT BE USED WHEN ECONOMIZER IS INSTALLED. UNIT FACTORY-SHIPPED IN STD MODE.

LEGEND

- | | | | |
|-------|------------------------------|--------|-----------------------|
| △ | FIELD SPLICE | DH | DEHUMIDIFICATION MODE |
| ○ | TERMINAL (MARKED) | DR | DEHUMIDIFICATION MODE |
| ○ | TERMINAL (UNMARKED) | DR | DEFROST RELAY |
| ○ | SPLICE | DR | ECONOMIZER |
| ○ | SPLICE (MARKED) | EQUIP | EQUIPMENT |
| --- | FACTORY WIRING | FU | FUSE |
| --- | FIELD CONTROL WIRING | GND | GROUND |
| --- | FIELD POWER WIRING | HPS | HIGH PRESSURE SWITCH |
| --- | ACCESSORY OR OPTIONAL WIRING | HR | HEATER RELAY |
| AT | AUTO TRANSFORMER | IFB | INDOOR FAN BOARD |
| C | CONTACTOR | IFM | INDOOR FAN MOTOR |
| CAP 1 | CAPACITOR, COMP | LPS | LOW PRESSURE SWITCH |
| CCH | CRANK CASE HEATER | OFM | OUTDOOR FAN MOTOR |
| COMP | COMPRESSOR MOTOR | OFR | OUTDOOR FAN RELAY |
| DB | DEFROST BOARD | RVS | REVERSING VALVE |
| DFT | DEFROST TEMPERATURE SWITCH | TRAN | TRANSFORMER |
| | | T-STAT | THERMOSTAT |
| | | R | ECON RELAY |
| | | R1 | ECON RELAY |
| | | STD | STANDARD MODE |

- COLOR CODE**
- | | |
|-----|--------|
| BLK | BLACK |
| BLU | BLUE |
| BRN | BROWN |
| GRY | GRAY |
| GRN | GREEN |
| ORN | ORANGE |
| PNK | PINK |
| RED | RED |
| VIO | VIOLET |
| WHT | WHITE |
| YEL | YELLOW |

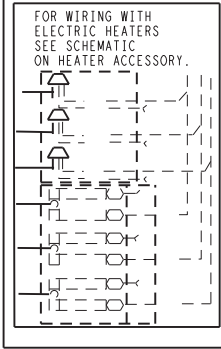
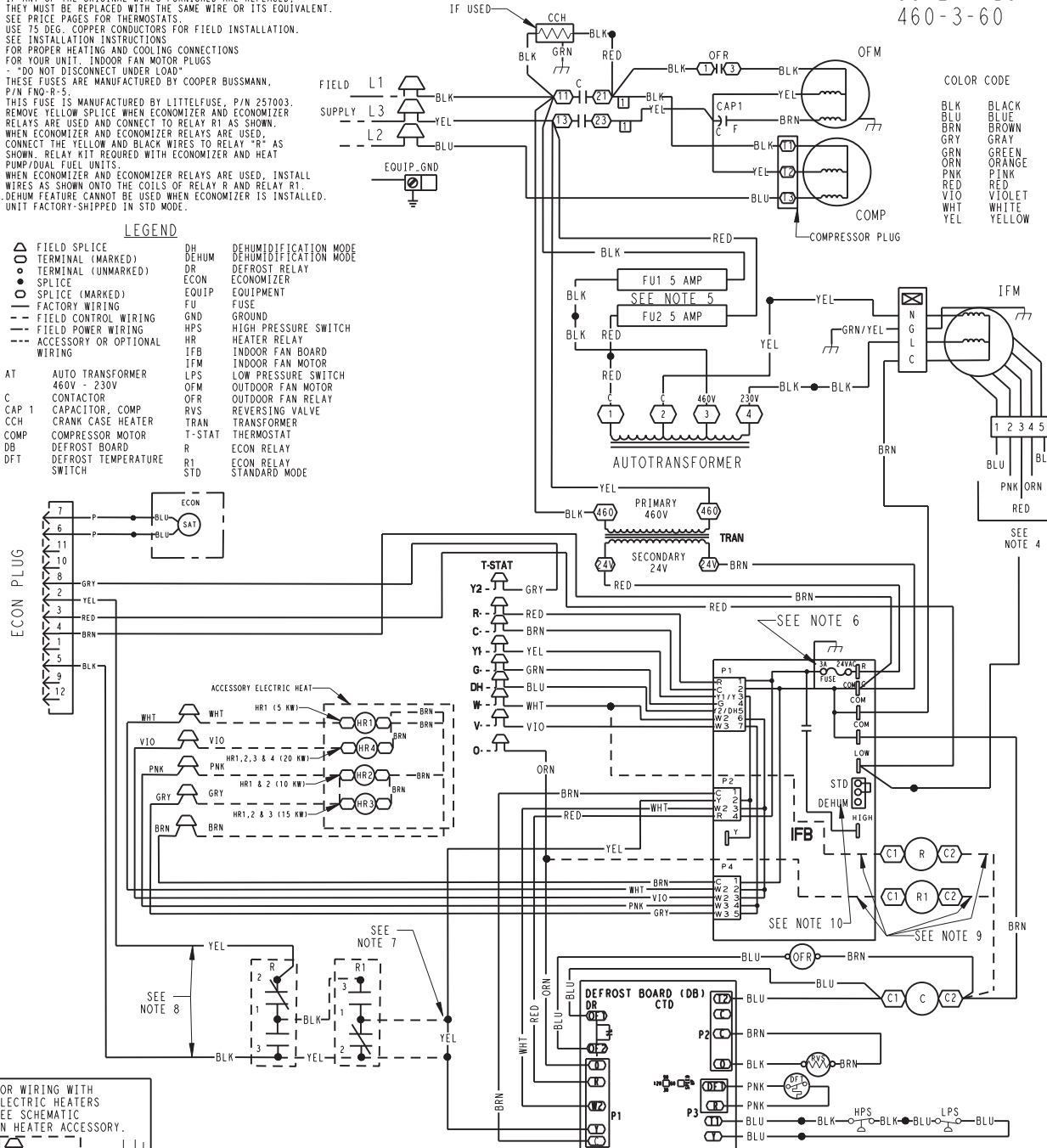

DIP SWITCH SETTINGS

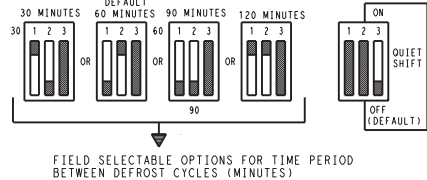

SPEED UP **JUMPERED TEST PINS (USE METAL OBJECT) FIELD SPEED-UP CYCLE**

- MOMENTARILY SHORT PINS AND RELEASE TO BYPASS COMPRESSOR OFF DELAY.
- SHORT FOR 5+ SEC. AND RELEASE FOR FORCED DEFROST.
- PERMANENT SHORT WILL BE IGNORED.

DEFROST WILL TERMINATE IN 30 SEC. IF DFT OPEN. DEFROST WILL TERMINATE NORMALLY IF DFT IS CLOSED. THE COMPRESSOR WILL SHUT OFF FOR 30 SEC. ON DEFROST INITIATION AND TERMINATION IN THE "QUIET SHIFT" ON POSITION

TYPICAL LADDER WIRING SCHEMATIC - 460-3-60

LADDER WIRING DIAGRAM

DANGER: ELECTRICAL SHOCK HAZARD DISCONNECT POWER BEFORE SERVICING

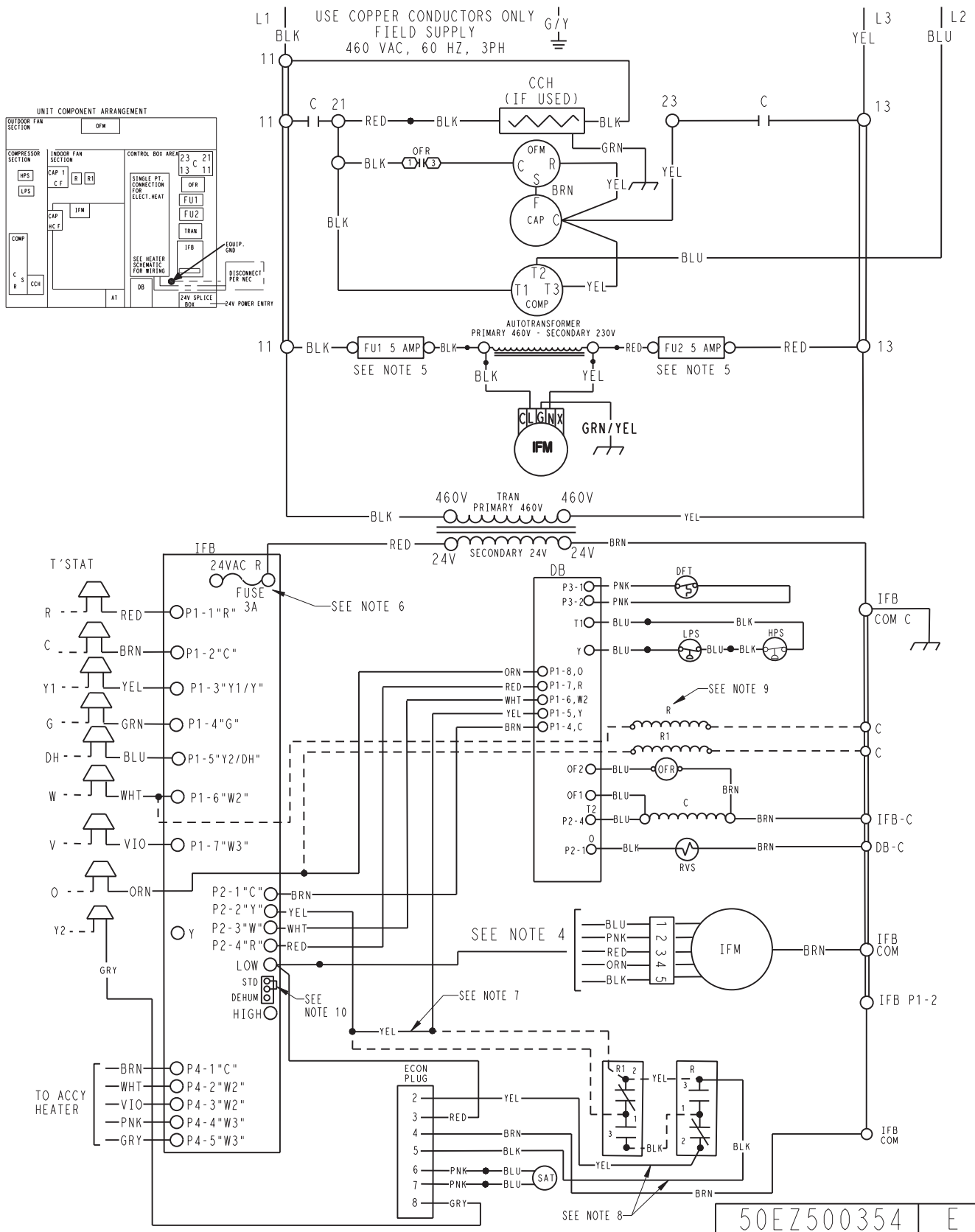

A10195L

CONTROLS

Operating sequence

When power is supplied to unit, the transformer (TRAN) is energized.

On units with crankcase heater, heater is also energized.

Cooling — With the thermostat in the cooling position, the thermostat makes circuit R-O. This energizes the reversing valve solenoid (RVS) and places the unit in standby condition for cooling.

As the space temperature rises, the thermostat closes circuit R-Y. A circuit is made to contactor (C), starting the compressor (COMP) and outdoor-fan motor (OFM). Circuit R-G is made at the same time and starts the indoor-fan motor (IFM).

When the thermostat is satisfied, contacts open, deenergizing C. The COMP and OFM stop, and the IFM stops after the preselected time delay.

Heating — On a call for heat, thermostat makes circuits R-Y and R-G.

A circuit is made to C, starting COMP and OFM. Circuit R-G also is completed, energizing IFR and starting IFM after the selected time delay.

Should room temperature continue to fall, circuit R-W is made through second-stage thermostat. If optional electric heat package is used, a relay is energized, bringing on first bank of supplemental electric heat. When thermostat is satisfied, contacts open, deenergizing contactor and relay; motors and heaters deenergize.

Defrost — Defrost board (DB) is a time and temperature control, which includes a field-selectable time period (dip switch 1 and 2 on the board) between checks for defrost (30, 60, 90, or 120 minutes). Electronic timer and defrost cycle start only when contactor is energized and defrost thermostat (DFT) is closed.

The defrost board is also equipped with a third dip switch for selecting Quiet Shift operation. The Quiet Shift operation turns compressor off at defrost initiation and termination. Unit is factory shipped with quiet shift turned off.

Defrost mode is identical to cooling mode, except outdoor fan motor stops and a bank of optional electric heat turns on to warm air supplying the conditioned space.

NOTE:

1. Compressor time delay occurs through the defrost control board.
2. Defrost control board has built in 5 minute compressor delay; once the compressor has started and then stopped, it cannot be restarted again until 5 minutes have elapsed.

GUIDE SPECIFICATIONS

Packaged Heat Pump System

HVAC Guide Specifications

Size Range: 2 to 5 Tons, Nominal Cooling

Part 1—General

SYSTEM DESCRIPTION

Outdoor, packaged, air-to-air heat pump unit utilizing a hermetic scroll compressor for cooling duty and optional electric heating. Unit shall discharge supply air vertically or horizontally as shown on contract drawings. Outdoor fan/coil section shall have a draw-thru design with vertical discharge for minimum sound levels.

QUALITY ASSURANCE

A. Unit shall be rated in accordance with AHRI Standards 210/240 and 270.

- B. Unit shall be designed in accordance with UL Standard 1995.
- C. Unit shall be manufactured in a facility registered to ISO 9001 manufacturing quality standard.
- D. Unit shall be UL listed and c-UL certified as a total package for safety requirements.
- E. Roof curb shall be designed to conform to NRCA Standards.
- F. Insulation and adhesives shall meet NFPA 90A requirements for flame spread and smoke generation.
- G. Cabinet insulation shall meet ASHRAE Standard 62P.

DELIVERY, STORAGE AND HANDLING

Unit shall be stored and handled per manufacturer's recommendations.

Part 2 — Products

EQUIPMENT

A. General:

Factory-assembled, single-piece, heat pump unit. Contained within the enclosure shall be all factory wiring, piping, controls, refrigerant charge (R-410A), and special features required prior to field start-up.

B. Unit Cabinet:

1. Unit cabinet shall be constructed of phosphated, zinc-coated, pre-painted steel capable of withstanding 500 hours of salt spray.
2. Normal service shall be through 3 removable cabinet panels.
3. The unit shall be constructed on a rust proof unit base that has an externally trapped, integrated sloped drain.
4. Indoor fan compartment top surface shall be insulated with a minimum 1/2-in. (13 mm) thick, flexible fiberglass insulation, coated on the air side and retained by adhesive and mechanical means. The indoor wall sections will be insulated with a minimum semi-rigid, foil-faced board capable of being wiped clean. Aluminum foil-faced fiberglass insulation shall be used in the entire indoor air cavity section.
5. Unit shall have a field-supplied condensate trap.
6. Metal Insulated Duct Covers for side discharge will be standard on all sizes.
7. Unit insulation conforms to ASHRAE 62P.

C. Fans:

1. The indoor fan shall be 5-speed, direct-drive, as shown on equipment drawings.
2. Fan wheel shall be made from steel and shall be double-inlet type with forward-curved blades with corrosion resistant finish. Fan wheel shall be dynamically balanced.
3. Outdoor fan shall be direct-drive, propeller-type with aluminum blades riveted to corrosion resistant steel spiders, be dynamically balanced, and discharge air vertically.

D. Compressor:

1. Fully hermetic compressors with factory-installed vibration isolation.
2. Scroll compressors shall be standard on all units.
3. Compressor Protection:
Defrost control shall protect compressor by preventing "short cycling."

E. Coils:

Indoor and outdoor coils shall have aluminum plate fins mechanically bonded to seamless copper tubes with all joints

brazed. Tube sheet openings shall be belled to prevent tube wear.

F. Refrigerant Metering Device:

Refrigerant metering device shall be thermostatic expansion valve for cooling, and fixed orifice for heating.

G. Filters:

Filter section shall consist of field-installed, throwaway, 1-in. (25 mm) – thick fiberglass filters of commercially available sizes.

H. Controls and Safeties:

1. Unit controls shall be complete with a self-contained, low-voltage control circuit.
2. Units shall incorporate an internal compressor protector that provides reset capability.

I. Operating Characteristics:

1. Unit shall be capable of starting and running at 125°F (51.7°C) ambient outdoor temperature.
2. Compressor with standard controls shall be capable of operation down to 40°F (4.4°C) ambient outdoor temperature in cooling mode.
3. Unit shall be provided with 90-second fan time delay after the thermostat is satisfied.

J. Electrical Requirements:

All unit power wiring shall enter the unit cabinet at a single location.

K. Motors:

1. Compressor motors shall be of the refrigerant-cooled type with line-break thermal and current overload protection.
2. All fan motors shall have permanently lubricated bearings, and inherent, automatic reset, thermal overload protection.
3. Condenser fan motor shall be totally enclosed.
4. Evaporator fan motor to be ECM Motor.

L. Special Features Available:

1. Coil Options:
Base unit with tin plated indoor coil hairpins available as a factory installed option.
2. Compressor Start Kit (single phase units only):
Shall provide additional starting torque for single-phase compressors.
3. Thermostat:
To provide for two-stage heating and one-stage cooling in addition manual or automatic changeover and indoor fan control.
4. Crankcase Heater:
Shall provide anti-floodback protection for lowload cooling applications.

5. Economizer:

(Horizontal – Field installed option)

(Vertical – Field installed accessory or factory installed option)

- a. Economizer controls capable of providing free cooling using outside air.
- b. Equipped with low leakage dampers not to exceed 3% leakage, at 1.0 IN. W.C. pressure differential.
- c. Spring return motor shuts off outdoor damper on power failure.

6. Electric Heaters

- a. Electric heater shall be available as a field installed option.
- b. Heater elements shall be open wire type, adequately supported and insulated with ceramic bushings.
- c. Electric heater packages must provide single point power connection capability.

7. Filter Rack Kit:

Shall provide filter mounting for downflow applications. Offered as an accessory or as a factory installed option.

8. Flat Roof Curb:

Curbs shall have seal strip and a wood nailer for flashing and shall be installed per manufacturer's instructions.

9. Low Ambient Package:

Shall consist of a solid-state control and outdoor coil temperature sensor for controlling outdoor-fan motor operation, which shall allow unit to operate down to 0°F (-17.7°C) outdoor ambient temperature.

10. Manual Outdoor Air Damper:

Package shall consist of damper, birdscreen, and rain-hood which can be preset to admit outdoor air for year-round ventilation.

11. Square-To-Round Duct Transitions (24-48 size):

Shall have the ability to convert the supply and return openings from rectangular to round.

12. Time Guard II

Automatically prevents the compressor from restarting for at least 4 minutes and 45 seconds after shutdown of the compressor. Not required when a corporate programmable thermostat is applied or with a RTU-MP control.

13. Dual Point Electric Heaters|

Allows you to power the electric heater and unit contactor separately by having two individual field power supply circuits connected respectively.

| PHD4 ACCESSORIES | | |
|--|---|------------|
| Accessory Model Number | Description | Use With |
| CURBS | | |
| CPRFCURB010A00 | Roof Curb, 11" High | 24 – 60 |
| CPRFCURB011A00 | Roof Curb, 14" High | 24 – 60 |
| CPRFCURB012A00 | Roof Curb, 11" High | 36 – 60 |
| CPRFCURB013A00 | Roof Curb, 14" High | 36 – 60 |
| Note: CPRFCURB010A00 AND CPRFCURB011A00 can be used with 42–60 size units with some overhang. | | |
| ADAPTER CURBS* | | |
| CPADCURB001A00 | Adapter curb for use with NPRFCURB006A00 & NPRFCURB007A00 | 24 – 30 |
| CPADCURB002A00 | Adapter curb for use with NPRFCURB008A00 & NPRFCURB009A00 | 36 – 60 |
| * Can also be used when replacing other manufacturer's older generation units that contain a composite base without a metal base rail. | | |
| CONCENTRIC ADAPTERS – (Use with curb only) | | |
| NPCONADP001A00 | For 18" round duct (use with curbs CPRFCURB010A00, CPRFCURB011A00) | Small Curb |
| NPCONADP002A00 | For 18" round duct (use with curbs CPRFCURB012A00, CPRFCURB013A00) | Large Curb |
| ECONOMIZERS | | |
| CPECOMZR007A00 | Dedicated Vertical Economizer – Internal with solid state controller, gear driven, fully modulating damper, spring return actuator, up to 50% barometric relief, supply and dry bulb outdoor air sensors. Includes filter rack with 1" filters*. | 24 – 30 |
| CPECOMZR008A00 | | 36 – 42 |
| CPECOMZR009A00 | | 48 – 60 |
| CPECOMZR010A00 | Dedicated Horizontal Economizer – Internal with solid state controller, fully modulating damper, spring return actuator, supply and dry bulb outdoor air sensor, and low ambient compressor lockout switch included. Includes filter rack with 1–inch filters*. | 24 – 30 |
| CPECOMZR011A00 | | 36 – 42 |
| CPECOMZR012A00 | | 48 – 60 |
| CPRLYKIT001A00 | Economizer Relay for Heat Pumps | 36 – 60 |
| AXB078ENT | Outdoor Enthalpy Control | ALL |
| * Outdoor enthalpy available as field installed accessory; Filter rack and 1" filter, same as CPFILTRK kit | | |
| DAMPERS | | |
| CPMANDPR007A00 | Manual Outside Air Damper (Includes filter rack and 1" filter, same as CPFILTRK kit) | 24 – 30 |
| CPMANDPR008A00 | | 36 – 42 |
| CPMANDPR009A00 | | 48 – 60 |
| INTERNAL FILTER RACKS | | |
| CPFILTRK007A00 | Internal Filter Rack (includes 1–inch filters) | 24 – 30 |
| CPFILTRK008A00 | | 36 – 42 |
| CPFILTRK009A00 | | 48 – 60 |
| CRANKCASE HEATERS | | |
| NPCRKHTR008A00 | 240V Crankcase Heater (included on all other sizes) | 36 |
| LOW AMBIENT, ANTI-CYCLE TIMER, COMPRESSOR START ASSIST | | |
| CPLOWAMB001A00 | Low Ambient Control – enables cooling system to operate down to 0 Deg. F by cycling condenser fan on and off. | ALL |
| NRTIMEGD001A00 | Five Minute Compressor Delay | ALL |
| CPHSTART002A00 | PTC Compressor Start Assist Kit (All single phase) | ALL |
| HAIL GUARDS / COIL PROTECTION (Factory installed on PHD4**000KTP models) | | |
| NAPA00701GR | 3/8" spacing dense wire grilles | 24 – 30 |
| NAPA00601GR | 3/8" spacing dense wire grilles | 36 |
| NAPA01001GR | 3/8" spacing dense wire grilles | 42 – 48 |
| NAPA01301GR | 3/8" spacing dense wire grilles | 60 |
| DUCT TRANSITIONS | | |
| NPDUCFLG002A00 | Square to Round (1 set of 2, use with horizontal duct flanges only) | 24 – 48 |

PHD4 ACCESSORIES (CONT.)

| ELECTRIC HEATERS | | | | |
|--|------------------------------|--------------|---------------|------------------|
| Voltage / Nominal Capacity kW / Fuses | | | | |
| PART NO. | NOMINAL CAPACITY (kW) | FUSED | STAGES | USED WITH |
| 208/230V – 1 PHASE – 60 HZ | | | | |
| CPHEATER052A0* | 3.8 / 5.0 | NO | 1 | 24 – 36 |
| CPHEATER064A0* | 3.8 / 5.0 | YES | 1 | ALL |
| CPHEATER070A0* | 5.4 / 7.2 | YES | 2 | ALL |
| CPHEATER050A0* | 7.5 / 10.0 | YES | 2 | ALL |
| CPHEATER066A0* | 11.3 / 15.0 | YES | 2 | 30 – 60 |
| CPHEATER054A0* | 15.0 / 20.0 | YES | 2 | 42 – 60 |
| 208/230V – 3 PHASE – 60 HZ | | | | |
| CPHEATER055A0* | 3.8 / 5.0 | NO | 2 | 30 – 60 |
| CPHEATER056A0* | 7.5 / 10.0 | NO | 2 | 30 – 42 |
| CPHEATER068A0* | 7.5 / 10.0 | YES | 2 | 30 – 60 |
| CPHEATER058A0* | 11.3 / 15.0 | YES | 2 | 30 – 60 |
| CPHEATER059A0* | 15.0 / 20.0 | YES | 2 | 42 – 60 |
| 460V – 3 PHASE – 60 HZ | | | | |
| CPHEATER061A0* | 10.0 | NO | 2 | 36 – 60 |
| CPHEATER062A0* | 15.0 | NO | 2 | 36 – 60 |
| CPHEATER063A0* | 20.0 | NO | 2 | 42 – 60 |

* Denotes digit can be 0, 1, or 2

NOTE: If installing an accessory heater, the thermostat must have capability to energize "G" (fan) on a call for "W" (electric heat). TSTAT0406 and TSTAT0408 contain this feature.